

Cartridge Heaters



hotset – High-Watt Density Cartridge Heaters

Hotset – High-Watt Density Cartridge Heaters – proven technology founded on our long term experience with many outstanding advantages. For applications in foundries, plastic processing, textile and packaging, medical, mechanical engineering, glass works and rubber processing as well as many other industries with specialized equipment.

Hotset – High-Watt Density Cartridge Heaters are the result of continuous product development of Low Watt Density brass and stainless steel heaters, as well as tubular heaters. The High-Watt density cartridge heater's main advantage is that they cover, within a limited amount of space, a high heat requirement and are therefore particularly suitable for application in Hot Runner Systems, Packaging jaws, Hot Melt Applications, Hot Box Systems and Goose-necks for Die Casting Machines, etc. A wide range of High-Watt Density Cartridge Heaters with various diameters and different wattages can be delivered from Hotset stock. The High-Watt Density Cartridge Heaters are also available designed and manufactured to individual customer requirements in addition to the stock range of products.

One of their outstanding features is their power consumption and power distribution can be adjusted to the individual task and can be accurately reproduced time and time again.

They also offer numerous different connection options. In addition, Hotset offers not only thermocouples and controllers, which correspond precisely with the cartridge heaters and other necessary accessories. This comprehensive range enables the customer to choose the most efficient solution to solve their individual heating task.

Hotset sales representatives are available at any time to discuss your specific heating element requirements, on site if required. Hotset offers High-Watt Density Cartridge Heaters with nineteen standard diameters, both imperial and metric sizes, built to your length, wattage and voltage requirements, up to 160 Watts per Square inch, available higher when needed. The lead and exit options can be designed to satisfy the customer's need, becoming a very cost effective technical solution.

The High-Watt Density Cartridge Heater dimensions depend entirely on the individual heating task. Factors such as purpose, the material to be heated, dimension and volume of material, voltage, maximum current, estimated power consumption, switching of heating elements, style and

length of connection, quantity required, type of temperature controller, location of thermocouple, and the heat up time needed must all be taken into consideration. Please use our "Technical Section" with the fundamental calculation formula and some examples of their use for an initial assessment. Please do not hesitate to contact your Hotset sales representative who will be happy to help you gather the necessary data for your particular application.

To master specific tasks, Hotset offers a range of innovative developments of the High-Watt Density Cartridge Heater: a built-in thermocouple allows exact temperature monitoring of the heated material, where space is restricted. The sensor selection depends on the operating temperature of the High-Watt Density Cartridge Heater and on the existing temperature controller. The type HI diameter 1/8" is especially suitable for the heating of small parts with standard voltage (not available with built-in thermocouple).

The Hotset High-Watt Density Cartridge Heater with integral cutting blade is used especially in the cutting of foils and plastic textile material. Their main features are the limited use of space and short heat up period. This heater can be changed quickly and easily should a problem occur.

All Hotset High-Watt Density Cartridge Heaters are checked and tested individually, regardless of whether they are manufactured for stock or specifically manufactured to customer requirements. The quality control measures include diameter and length tolerance, resistance and high voltage stability testing of the cold heater. Hotset Corporation has CE, CSA and UL approval on our cartridge heaters.

SAFETY & MAINTENANCE INSTALLATION GUIDELINES

Installation/Removal:

1. Use non-conductive sprays and pastes for installation of cartridge heaters.
2. A through hole bore is recommended for ease of removal. (Consult factory for hole-size recommendation.)
3. Install leads away from sharp edge and parts as this may cause short circuits.
4. Be sure your controller corresponds to the needed power consumption and the temperature sensor used for the heater. Your controller should have soft-start/ramp-soak capabilities for slow heat-up to burn off any moisture which may have entered the heating element.
5. Ground all tools.
6. Make sure your heater has a good tight

fit in the cavity – this creates the best heat transfer.

7. When removing heater, use caution, as it may still be hot. The use of a knockout tab, or right angle block may ease with removal.

Safety:

1. Store heaters in a dry place at room temperature.
2. Ensure that no liquids or gasses can enter the lead area of the heater, except where the connection has been specifically designed for this purpose - exposure to liquids and gases may cause a short circuit.
3. Establish maintenance procedures for all handling of heating elements. Be sure all maintenance personnel are aware that these do carry electrical currents.
4. **HEATERS BECOME EXTREMELY HOT WHILE IN OPERATION - DO NOT TOUCH WHILE IN USE!!!!**

Table of Contents

	PAGE
HI – High-Watt Density Cartridge Heater	1
High-Watt Density Cartridge Heater Stock List – U.S.	2 - 8
High-Watt Density Cartridge Heater Stock List – Germany	9 - 15
HJ/HK – High-Watt Density Cartridge Heater with Thermocouple – Type J/K.....	16
High-Watt Density Cartridge Heater with Thermocouple Stock List – U.S.	17
High-Watt Density Cartridge Heater with Thermocouple Stock List – Germany	18
4mm High-Watt Density Cartridge Heater.....	19
High-Watt Density Cartridge Heater with Cutting Blade.....	20
LI – Medium Watt Density Cartridge Heater.....	21
Medium Watt Density Cartridge Heater Stock List – Germany.....	22
NP – Low Watt Density Cartridge Heater	23
Lead Options.....	24
Lead Connection Options	25 - 26
Re-ordering Information	27
Cartridge Heater Technical Information.....	28

HI

HIGH WATT DENSITY CARTRIDGE HEATER

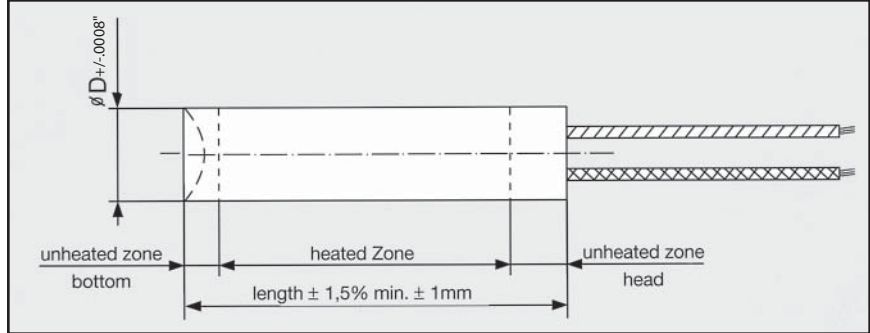

DIAMETERS AVAILABLE

IMPERIAL	1/8"	1/4"	3/8"	5/16"	1/2"	5/8"	11/16"	3/4"	1"
METRIC	6.5	8	9.5	10	12	12.5	15	16	
	18	19	20	25					

*Special diameter available, consult factory

Standard details:

Diameter

Length

Gas tight welded tip

Stock heaters available

Lead Connection Option: Crimped leads or swaged leads

Lead and type of connection leads, 10" fiberglass (standard)

Imperial diameters 1/8" up to 1";

Metric diameters 6.5mm to 25.1mm (see table above)

Minimum length of 1 1/2", maximum length to 105"

Maximum wattage depends on heater's size and application

Standard delivery for non-stock items is 10 to 15 working days

UL/CSA/CE

Order Details (Example)

Diameter: 1/2"

Length: 6"

Voltage: 240

Wattage: 800

Lead Connection: Swaged

Lead Type: Fiberglass

Lead Protection: Braided Metal Sleeving

Options:

1. Lead connection option and lead protection
2. Lead length and type (not applicable for some stock types)
3. Different voltage and wattage
4. Specialized wattage distribution
5. Diameter and length other than stock range
6. Heater tip flat bottom
7. With built-in thermocouple (See Type HJ/HK)
8. Restriction of diameter tolerance



Stock List: High-Watt Density Cartridge Heaters

PART #	DIAM.	LENGTH IN.	LENGTH MM	VOLTAGE	WATTAGE	LEAD LENGTH	CONNECTION
0880	3/8"	1.5	38.1	120	150	10"	CRIMPED
0881	3/8"	1.5	38.1	120	250	10"	CRIMPED
0882	3/8"	1.5	38.1	240	200	10"	CRIMPED
0883	3/8"	1.5	38.1	240	125	10"	CRIMPED
0884	3/8"	1.5	38.1	240	150	10"	CRIMPED
0885	3/8"	1.5	38.1	240	200	10"	CRIMPED
0886	3/8"	1.5	38.1	240	250	10"	CRIMPED
0887	3/8"	2.0	50.8	120	150	10"	CRIMPED
0888	3/8"	2.0	50.8	120	200	10"	CRIMPED
0889	3/8"	2.0	50.8	120	250	10"	CRIMPED
08903/8"	2.0	50.8	240	150	10"	CRIMPED	
08913/8"	2.0	50.8	240	200	10"	CRIMPED	
08923/8"	2.0	50.8	240	250	10"	CRIMPED	
0893	3/8"	2.5	63.5	120	200	10"	CRIMPED
0894	3/8"	2.5	63.5	120	300	10"	CRIMPED
0895	3/8"	2.5	63.5	240	200	10"	CRIMPED
0896	3/8"	2.5	63.5	240	300	10"	CRIMPED
0897	3/8"	3.0	76.2	120	200	10"	CRIMPED
0898	3/8"	3.0	76.2	120	400	10"	CRIMPED
0899	3/8"	3.0	76.2	240	200	10"	CRIMPED
0900	3/8"	3.0	76.2	240	300	10"	CRIMPED
0901	3/8"	3.0	76.2	240	400	10"	CRIMPED
0902	3/8"	3.5	88.9	120	250	10"	CRIMPED
0903	3/8"	3.5	88.9	120	500	10"	CRIMPED
0904	3/8"	3.5	88.9	240	250	10"	CRIMPED
0905	3/8"	3.5	88.9	240	500	10"	CRIMPED
0906	3/8"	4.0	101.6	120	250	10"	CRIMPED
0907	3/8"	4.0	101.6	120	300	10"	CRIMPED
0908	3/8"	4.0	101.6	120	500	10"	CRIMPED
0909	3/8"	4.0	101.6	240	250	10"	CRIMPED
0910	3/8"	4.0	101.6	240	500	10"	CRIMPED
0911	3/8"	4.0	101.6	240	250	10"	CRIMPED
0912	3/8"	4.0	101.6	240	350	10"	CRIMPED
0913	3/8"	4.0	101.6	240	400	10"	CRIMPED
0914	3/8"	4.0	101.6	240	500	10"	CRIMPED
1423	3/8"	4.0	101.6	240	600	10"	CRIMPED
0915	3/8"	5.0	127.0	120	300	10"	CRIMPED
0916	3/8"	5.0	127.0	120	500	10"	CRIMPED
0917	3/8"	5.0	127.0	240	300	10"	CRIMPED
0918	3/8"	5.0	127.0	240	500	10"	CRIMPED
0919	3/8"	5.0	127.0	240	750	10"	CRIMPED
0920	3/8"	5.5	139.7	240	600	10"	CRIMPED
0921	3/8"	6.0	152.4	120	400	10"	CRIMPED
0922	3/8"	6.0	152.4	120	600	10"	CRIMPED
0923	3/8"	6.0	152.4	240	500	10"	CRIMPED
0924	3/8"	6.0	152.4	240	705	10"	CRIMPED
0925	3/8"	6.0	152.4	240	400	10"	CRIMPED
0926	3/8"	6.0	152.4	240	600	10"	CRIMPED
0927	3/8"	6.5	165.1	240	600	10"	CRIMPED
0928	3/8"	7.0	177.8	120	600	10"	CRIMPED
0929	3/8"	7.0	177.8	240	600	10"	CRIMPED
0930	3/8"	7.0	177.8	240	700	10"	CRIMPED
0931	3/8"	7.0	177.8	240	750	10"	CRIMPED

*Same day shipping orders must be received by 1:00 PM to meet carrier deadlines.

* Subject to prior sales.

UL/CSA/CE



Stock List: High-Watt Density Cartridge Heaters

PART #	DIAM.	LENGTH IN.	LENGTH MM	VOLTAGE	WATTAGE	LEAD LENGTH	CONNECTION
0932	3/8"	7.5	190.5	240	600	10"	CRIMPED
0933	3/8"	8.0	203.2	120	600	10"	CRIMPED
0934	3/8"	8.0	203.2	240	500	10"	CRIMPED
0935	3/8"	8.0	203.2	240	600	10"	CRIMPED
0936	3/8"	9.3	235.0	240	1000	10"	CRIMPED
0937	3/8"	10.0	254.0	120	500	10"	CRIMPED
0938	3/8"	10.0	254.0	120	600	10"	CRIMPED
0939	3/8"	10.0	254.0	120	1000	10"	CRIMPED
0940	3/8"	10.0	254.0	240	600	10"	CRIMPED
0941	3/8"	10.0	254.0	240	1000	10"	CRIMPED
09423/8"	12.0	304.8	120	600	10"	CRIMPED	
09433/8"	12.0	304.8	120	1000	10"	CRIMPED	
09443/8"	12.0	304.8	240	600	10"	CRIMPED	
0945	3/8"	12.0	304.8	240	1000	10"	CRIMPED
0946	3/8"	12.0	304.8	240	1200	10"	CRIMPED
0947	1/2"	1.5	38.1	120	150	10"	CRIMPED
0948	1/2"	1.5	38.1	120	200	10"	CRIMPED
0949	1/2"	1.5	38.1	240	150	10"	CRIMPED
0950	1/2"	1.5	38.1	240	200	10"	CRIMPED
0951	1/2"	2.0	50.8	120	200	10"	CRIMPED
0952	1/2"	2.0	50.8	120	300	10"	CRIMPED
0953	1/2"	2.0	50.8	240	200	10"	CRIMPED
0954	1/2"	2.0	50.8	240	300	10"	CRIMPED
0955	1/2"	2.4	60.3	120	120	10"	CRIMPED
0956	1/2"	2.5	63.5	120	250	10"	CRIMPED
0957	1/2"	2.5	63.5	120	400	10"	CRIMPED
0958	1/2"	2.5	63.5	240	250	10"	CRIMPED
0959	1/2"	2.5	63.5	240	400	10"	CRIMPED
0960	1/2"	2.5	63.5	240	400	10"	CRIMPED
0961	1/2"	3.0	76.2	120	250	10"	CRIMPED
0962	1/2"	3.0	76.2	120	350	10"	CRIMPED
0963	1/2"	3.0	76.2	120	400	10"	CRIMPED
0964	1/2"	3.0	76.2	120	150	10"	CRIMPED
0965	1/2"	3.0	76.2	120	250	10"	CRIMPED
0966	1/2"	3.0	76.2	120	300	10"	CRIMPED
0967	1/2"	3.0	76.2	120	400	10"	CRIMPED
0968	1/2"	3.0	76.2	120	500	10"	CRIMPED
0969	1/2"	3.5	88.9	120	250	10"	CRIMPED
0970	1/2"	3.5	88.9	120	500	10"	CRIMPED
0971	1/2"	3.5	88.9	240	250	10"	CRIMPED
0972	1/2"	3.5	88.9	240	350	10"	CRIMPED
0973	1/2"	3.5	88.9	240	500	10"	CRIMPED
0974	1/2"	4.0	101.6	120	250	10"	CRIMPED
0975	1/2"	4.0	101.6	120	500	10"	CRIMPED
0976	1/2"	4.0	101.6	240	300	10"	CRIMPED
0977	1/2"	4.0	101.6	240	400	10"	CRIMPED
0978	1/2"	4.0	101.6	240	500	10"	CRIMPED
0979	1/2"	4.0	101.6	240	750	10"	CRIMPED
0980	1/2"	5.0	127.0	240	350	10"	CRIMPED
0981	1/2"	5.0	127.0	120	500	10"	CRIMPED
0982	1/2"	5.0	127.0	240	500	10"	CRIMPED
0983	1/2"	5.0	127.0	240	350	10"	CRIMPED
0984	1/2"	5.0	127.0	240	400	10"	CRIMPED

*Same day shipping orders must be received by 1:00 PM to meet carrier deadlines.

*Subject to prior sales.

UL/CSA/CE



Stock List: High-Watt Density Cartridge Heaters

PART #	DIAM.	LENGTH IN.	LENGTH MM	VOLTAGE	WATTAGE	LEAD LENGTH	CONNECTION
0985	1/2"	5.5	139.7	120	500	10"	CRIMPED
0986	1/2"	5.5	139.7	240	500	10"	CRIMPED
0987	1/2"	6.0	152.4	120	500	10"	CRIMPED
0988	1/2"	6.0	152.4	120	600	10"	CRIMPED
0989	1/2"	6.0	152.4	120	750	10"	CRIMPED
0990	1/2"	6.0	152.4	120	1000	10"	CRIMPED
0991	1/2"	6.0	152.4	240	500	10"	CRIMPED
0992	1/2"	6.0	152.4	240	750	10"	CRIMPED
0993	1/2"	6.0	152.4	240	1000	10"	CRIMPED
0994	1/2"	6.0	152.4	240	700	10"	CRIMPED
09951/2"	6.5	165.1	240	500	10"	CRIMPED	
09961/2"	6.5	165.1	240	700	10"	CRIMPED	
09971/2"	7.0	177.8	120	600	10"	CRIMPED	
0998	1/2"	7.0	177.8	240	600	10"	CRIMPED
0999	1/2"	7.0	177.8	240	500	10"	CRIMPED
1000	1/2"	7.0	177.8	240	750	10"	CRIMPED
1001	1/2"	7.0	177.8	240	1000	10"	CRIMPED
1002	1/2"	7.1	181.0	240	600	10"	CRIMPED
1003	1/2"	7.1	181.0	240	1000	10"	CRIMPED
1004	1/2"	8.0	203.2	120	500	10"	CRIMPED
1005	1/2"	8.0	203.2	120	750	10"	CRIMPED
1006	1/2"	8.0	203.2	120	1000	10"	CRIMPED
1007	1/2"	8.0	203.2	240	1500	10"	CRIMPED
1008	1/2"	8.0	203.2	240	500	10"	CRIMPED
1009	1/2"	8.0	203.2	240	750	10"	CRIMPED
1010	1/2"	8.0	203.2	240	1000	10"	CRIMPED
1011	1/2"	8.3	209.6	120	1500	10"	CRIMPED
1012	1/2"	9.0	228.6	120	1000	10"	CRIMPED
1013	1/2"	10.0	254.0	240	1000	10"	CRIMPED
1014	1/2"	10.0	254.0	240	2000	10"	CRIMPED
1015	1/2"	12.0	304.8	120	1000	10"	CRIMPED
1016	1/2"	12.0	304.8	240	1000	10"	CRIMPED
1018	5/8"	1.2	30.5	120	200	10"	CRIMPED
1019	5/8"	1.3	31.8	240	250	10"	CRIMPED
1025	5/8"	1.5	38.1	120	200	10"	CRIMPED
1027	5/8"	1.5	38.1	120	200	10"	CRIMPED
1020	5/8"	2.0	50.8	120	200	10"	CRIMPED
1021	5/8"	2.0	50.8	240	200	10"	CRIMPED
1022	5/8"	2.0	50.8	240	400	10"	CRIMPED
1023	5/8"	2.3	57.2	120	250	10"	CRIMPED
1024	5/8"	2.3	57.2	240	250	10"	CRIMPED
1026	5/8"	2.5	63.5	120	275	10"	CRIMPED
1028	5/8"	2.5	63.5	240	275	10"	CRIMPED
1029	5/8"	3.0	76.2	120	250	10"	CRIMPED
1030	5/8"	3.0	76.2	120	500	10"	CRIMPED
1031	5/8"	3.0	76.2	240	250	10"	CRIMPED
1032	5/8"	3.0	76.2	240	500	10"	CRIMPED
1033	5/8"	4.0	101.6	120	250	10"	CRIMPED
1034	5/8"	4.0	101.6	120	500	10"	CRIMPED
1035	5/8"	4.0	101.6	240	500	10"	CRIMPED
1036	5/8"	4.0	101.6	240	750	10"	CRIMPED
1037	5/8"	4.0	101.6	240	1000	10"	CRIMPED
1038	5/8"	4.0	101.6	240	250	10"	CRIMPED

*Same day shipping orders must be received by 1:00 PM to meet carrier deadlines.

*Subject to prior sales.

UL/CSA/CE



Stock List: High-Watt Density Cartridge Heaters

PART #	DIAM.	LENGTH IN.	LENGTH MM	VOLTAGE	WATTAGE	LEAD LENGTH	CONNECTION
1039	5/8"	5.0	127.0	240	500	10"	CRIMPED
1040	5/8"	5.0	127.0	240	750	10"	CRIMPED
1041	5/8"	6.0	152.4	240	500	10"	CRIMPED
1042	5/8"	6.0	152.4	240	1000	10"	CRIMPED
1043	5/8"	6.0	152.4	240	1500	10"	CRIMPED
1044	5/8"	7.0	177.8	120	500	10"	CRIMPED
1045	5/8"	7.0	177.8	240	500	10"	CRIMPED
1046	5/8"	7.0	177.8	240	1000	10"	CRIMPED
1047	5/8"	8.0	203.2	120	500	10"	CRIMPED
1048	5/8"	8.0	203.2	120	1000	10"	CRIMPED
10495/8"	8.0	203.2	240	500	10"	CRIMPED	
10505/8"	8.0	203.2	240	1000	10"	CRIMPED	
10515/8"	8.0	203.2	240	2000	10"	CRIMPED	
1052	5/8"	10.0	254.0	120	1000	10"	CRIMPED
1053	5/8"	10.0	254.0	120	1500	10"	CRIMPED
1054	5/8"	10.0	254.0	240	1000	10"	CRIMPED
1055	5/8"	10.0	254.0	240	1500	10"	CRIMPED
1056	5/8"	12.0	304.8	240	1250	10"	CRIMPED
1057	5/8"	12.0	304.8	240	1000	10"	CRIMPED
1058	5/8"	12.0	304.8	240	1500	10"	CRIMPED
1059	3/4"	2.5	63.5	120	350	10"	CRIMPED
1060	3/4"	2.5	63.5	240	250	10"	CRIMPED
1061	3/4"	2.5	63.5	240	350	10"	CRIMPED
1062	3/4"	3.0	76.2	120	250	10"	CRIMPED
1063	3/4"	3.0	76.2	240	250	10"	CRIMPED
1064	3/4"	3.0	76.2	240	500	10"	CRIMPED
1065	3/4"	4.0	101.6	120	250	10"	CRIMPED
1066	3/4"	4.0	101.6	240	500	10"	CRIMPED
1067	3/4"	5.0	127.0	120	300	10"	CRIMPED
1068	3/4"	5.0	127.0	240	1000	10"	CRIMPED
1069	3/4"	6.0	152.4	120	500	10"	CRIMPED
1070	3/4"	6.0	152.4	240	500	10"	CRIMPED
1071	3/4"	6.0	152.4	240	1000	10"	CRIMPED
1072	3/4"	7.5	190.5	240	800	10"	CRIMPED
1073	3/4"	8.0	203.2	120	500	10"	CRIMPED
1074	3/4"	8.0	203.2	240	1000	10"	CRIMPED
1075	3/4"	8.0	203.2	240	2000	10"	CRIMPED
1076	3/4"	9.0	228.6	240	800	10"	CRIMPED
1077	3/4"	9.0	228.6	240	1000	10"	CRIMPED
1078	3/4"	9.0	228.6	240	1500	10"	CRIMPED
1079	3/4"	10.0	254.0	240	2000	10"	CRIMPED
1080	3/4"	11.0	279.4	240	1000	10"	CRIMPED
1081	3/4"	12.0	304.8	240	1000	10"	CRIMPED
1082	3/4"	12.0	304.8	240	2000	10"	CRIMPED

*Same day shipping orders must be received by 1:00 PM to meet carrier deadlines.

*Subject to prior sales.

UL/CSA/CE



Stock List: High-Watt Density Cartridge Heaters

PART #	DIAM.	LENGTH IN.	LENGTH MM	VOLTAGE	WATTAGE	LEAD LENGTH	CONNECTION
1099	1/4"	1.0	25.4	110	75	10"	SWAGED
1100	1/4"	1.0	25.4	110	100	10"	SWAGED
1101	1/4"	1.0	25.4	120	150	10"	SWAGED
1102	1/4"	1.0	25.4	120	200	10"	SWAGED
1103	1/4"	1.0	25.4	240	200	10"	SWAGED
1104	1/4"	1.0	25.4	240	200	10"	SWAGED
1105	1/4"	1.3	25.4	110	150	10"	SWAGED
1106	1/4"	1.5	38.1	120	150	10"	SWAGED
1107	1/4"	1.5	38.1	120	175	10"	SWAGED
1108	1/4"	1.5	38.1	120	200	10"	SWAGED
1109 1/4"	1.5	38.1	120	250	10"	SWAGED	
1110 1/4"	1.5	38.1	240	175	10"	SWAGED	
1111 1/4"	1.5	38.1	240	200	10"	SWAGED	
1112	1/4"	2.0	50.8	120	150	10"	SWAGED
1113	1/4"	2.0	50.8	120	200	10"	SWAGED
1114	1/4"	2.0	50.8	120	250	10"	SWAGED
1116	1/4"	2.0	50.8	240	150	10"	SWAGED
1117	1/4"	2.0	50.8	240	200	10"	SWAGED
1118	1/4"	2.0	50.8	240	250	10"	SWAGED
1119	1/4"	2.0	50.8	240	300	10"	SWAGED
1120	1/4"	2.5	63.5	120	250	10"	SWAGED
1121	1/4"	2.5	63.5	240	180	10"	SWAGED
1122	1/4"	2.5	63.5	240	200	10"	SWAGED
1123	1/4"	2.5	63.5	240	300	10"	SWAGED
1124	1/4"	2.5	63.5	240	250	10"	SWAGED
1125	1/4"	3.0	76.2	120	200	10"	SWAGED
1126	1/4"	3.0	76.2	120	300	10"	SWAGED
1127	1/4"	3.0	76.2	240	200	10"	SWAGED
1128	1/4"	3.0	76.2	240	300	10"	SWAGED
1129	1/4"	4.0	101.6	120	200	10"	SWAGED
1130	1/4"	4.0	101.6	120	300	10"	SWAGED
1131	1/4"	4.0	101.6	240	350	10"	SWAGED
1132	1/4"	4.0	101.6	240	200	10"	SWAGED
1133	1/4"	4.0	101.6	240	300	10"	SWAGED
1134	1/4"	4.0	101.6	240	400	10"	SWAGED
1135	1/4"	5.0	127.0	240	750	10"	SWAGED
1136	1/4"	5.0	127.0	240	350	10"	SWAGED
1137	1/4"	5.0	127.0	240	480	10"	SWAGED
1138	1/4"	5.0	127.0	240	500	10"	SWAGED
1139	1/4"	5.8	146.1	240	350	10"	SWAGED
1140	1/4"	6.0	152.4	240	800	10"	SWAGED
1144	3/8"	1.0	25.4	120	200	10"	SWAGED
1145	3/8"	1.5	38.1	120	150	10"	SWAGED
1146	3/8"	1.5	38.1	120	250	10"	SWAGED
1147	3/8"	1.5	38.1	120	100	10"	SWAGED
1148	3/8"	1.5	38.1	120	250	10"	SWAGED
1149	3/8"	1.5	38.1	240	200	10"	SWAGED
1185	3/8"	1.5	38.1	240	250	10"	SWAGED
1150	3/8"	1.8	44.5	240	225	10"	SWAGED
1151	3/8"	2.0	50.8	120	150	10"	SWAGED
1152	3/8"	2.0	50.8	120	250	10"	SWAGED
1153	3/8"	2.0	50.8	240	150	10"	SWAGED
1154	3/8"	2.0	50.8	240	200	10"	SWAGED

*Same day shipping orders must be received by 1:00 PM to meet carrier deadlines.

*Subject to prior sales.

UL/CSA/CE



Stock List: High-Watt Density Cartridge Heaters

PART #	DIAM.	LENGTH IN.	LENGTH MM	VOLTAGE	WATTAGE	LEAD LENGTH	CONNECTION
1155	3/8"	2.0	50.8	240	250	10"	SWAGED
1156	3/8"	2.5	63.5	120	200	10"	SWAGED
1157	3/8"	2.5	63.5	240	300	10"	SWAGED
1158	3/8"	2.5	63.5	120	300	10"	SWAGED
1159	3/8"	2.5	63.5	240	200	10"	SWAGED
1182	3/8"	2.5	63.5	240	250	10"	SWAGED
1160	3/8"	2.5	63.5	240	150	10"	SWAGED
1161	3/8"	3.0	76.2	120	200	10"	SWAGED
1162	3/8"	3.0	76.2	120	400	10"	SWAGED
1163	3/8"	3.0	76.2	240	250	10"	SWAGED
11643/8"	3.5	88.9	240	250	10"	SWAGED	
11653/8"	3.5	88.9	240	500	10"	SWAGED	
11863/8"	4.0	101.6	120	250	10"	SWAGED	
1166	3/8"	4.0	101.6	120	400	10"	SWAGED
1167	3/8"	4.0	101.6	240	250	10"	SWAGED
1168	3/8"	4.0	101.6	240	400	10"	SWAGED
1169	3/8"	4.0	101.6	240	500	10"	SWAGED
1170	3/8"	5.0	127.0	120	300	10"	SWAGED
1171	3/8"	5.0	127.0	120	500	10"	SWAGED
1172	3/8"	5.0	127.0	240	500	10"	SWAGED
1173	3/8"	6.0	152.4	120	500	10"	SWAGED
1174	3/8"	6.0	152.4	120	600	10"	SWAGED
1176	3/8"	6.0	152.4	240	500	10"	SWAGED
1177	3/8"	6.0	152.4	240	750	10"	SWAGED
1178	3/8"	7.0	177.8	240	600	10"	SWAGED
1179	3/8"	8.0	203.2	120	300	10"	SWAGED
1181	3/8"	8.0	203.2	220	500	10"	SWAGED
1183	3/8"	10.0	254.0	240	1000	10"	SWAGED
1184	3/8"	12.0	304.8	240	1000	10"	SWAGED
1189	1/2"	1.5	38.1	120	200	10"	SWAGED
1190	1/2"	1.5	38.1	120	200	10"	SWAGED
1191	1/2"	1.5	38.1	120	200	10"	SWAGED
1192	1/2"	2.5	63.5	240	400	10"	SWAGED
1193	1/2"	2.5	63.5	240	250	10"	SWAGED
1194	1/2"	3.5	63.5	240	500	10"	SWAGED
1195	1/2"	4.0	101.6	120	500	10"	SWAGED
1196	1/2"	4.0	101.6	240	250	10"	SWAGED
1197	1/2"	4.5	114.3	240	350	10"	SWAGED
1198	1/2"	5.0	127.0	240	400	10"	SWAGED
1199	1/2"	5.0	127.0	240	750	10"	SWAGED
1200	1/2"	5.0	127.0	240	350	10"	SWAGED
1201	1/2"	5.0	127.0	240	500	10"	SWAGED
1202	1/2"	5.0	127.0	240	750	10"	SWAGED
1203	1/2"	5.5	139.7	240	500	10"	SWAGED
1204	1/2"	6.0	152.4	120	500	10"	SWAGED
1205	1/2"	6.0	152.4	120	600	10"	SWAGED
1206	1/2"	6.0	152.4	240	500	10"	SWAGED
1207	1/2"	6.0	152.4	240	1000	10"	SWAGED
1208	1/2"	6.0	152.4	240	700	10"	SWAGED
1209	1/2"	6.5	165.1	240	700	10"	SWAGED

*Same day shipping orders must be received by 1:00 PM to meet carrier deadlines.

*Subject to prior sales.

UL/CSA/CE



Stock List: High-Watt Density Cartridge Heaters

PART #	DIAM.	LENGTH IN.	LENGTH MM	VOLTAGE	WATTAGE	LEAD LENGTH	CONNECTION
1210	1/2"	7.0	177.8	240	750	10"	SWAGED
1211	1/2"	7.0	177.8	240	1000	10"	SWAGED
1212	1/2"	7.0	177.8	240	1500	10"	SWAGED
1213	1/2"	7.0	177.8	240	500	10"	SWAGED
1215	1/2"	8.0	203.2	240	1500	10"	SWAGED
1216	1/2"	8.0	203.2	240	500	10"	SWAGED
1217	1/2"	8.0	203.2	240	1000	10"	SWAGED
1218	1/2"	9.0	228.6	240	1000	10"	SWAGED
1219	1/2"	10.0	254.0	240	1000	10"	SWAGED
1220	1/2"	10.0	254.0	240	1500	10"	SWAGED
1221 1/2"	12.0	304.8	240	1000	10"	SWAGED	
1222 1/2"	12.0	304.8	240	1500	10"	SWAGED	
1233 5/8"	1.3	31.8	120	200	10"	SWAGED	
1234	5/8"	1.3	31.8	240	250	10"	SWAGED
1235	5/8"	1.5	38.1	120	250	10"	SWAGED
1236	5/8"	2.0	50.8	240	400	10"	SWAGED
1237	5/8"	2.0	50.8	240	500	10"	SWAGED
1238	5/8"	2.0	50.8	240	200	10"	SWAGED
1239	5/8"	3.0	76.2	120	250	10"	SWAGED
1240	5/8"	3.0	76.2	120	500	10"	SWAGED
1241	5/8"	6.0	152.4	240	1500	10"	SWAGED
1242	5/8"	7.0	177.8	240	500	10"	SWAGED
1243	5/8"	8.0	203.2	240	500	10"	SWAGED
1244	5/8"	10.0	254.0	240	1000	10"	SWAGED
1245	5/8"	11.0	279.4	120	250	10"	SWAGED
1246	3/4"	8.0	203.2	240	1000	10"	SWAGED
1247	3/4"	6.0	152.4	240	500	10"	SWAGED
1248	3/4"	6.0	152.4	240	1000	10"	SWAGED
1249	3/4"	7.5	190.5	240	800	10"	SWAGED
1250	3/4"	8.0	203.2	240	1000	10"	SWAGED
1251	3/4"	9.0	228.6	240	1000	10"	SWAGED
1252	3/4"	10.0	254.0	240	2000	10"	SWAGED
1254	3/4"	12.0	304.8	240	1000	10"	SWAGED



*Same day shipping orders must be received by 1:00 PM to meet carrier deadlines.

*Subject to prior sales.

UL/CSA/CE

Stock List: High-Watt Density Cartridge Heaters

PART #	DIAMETER	LENGTH	VOLTAGE	WATTAGE	LEAD CONNECTION	LEAD TYPE
4010404	6.5	40	230	100	10" SWAGED	FIBERGLASS
4010405	6.5	40	230	125	10" SWAGED	FIBERGLASS
4010410	6.5	40	230	160	10" SWAGED	FIBERGLASS
4010411	6.5	40	230	175	10" SWAGED	FIBERGLASS
4010415	6.5	40	230	200	10" SWAGED	FIBERGLASS
4010504	6.5	50	230	100	10" SWAGED	FIBERGLASS
4010510	6.5	50	230	160	10" SWAGED	FIBERGLASS
4010515	6.5	50	230	200	10" SWAGED	FIBERGLASS
4010517	6.5	50	230	250	10" SWAGED	FIBERGLASS
4010605	6.5	60	230	125	10" SWAGED	FIBERGLASS
4010610	6.5	60	230	160	10" SWAGED	FIBERGLASS
4010615	6.5	60	230	200	10" SWAGED	FIBERGLASS
4010617	6.5	60	230	250	10" SWAGED	FIBERGLASS
4010805	6.5	80	230	125	10" SWAGED	FIBERGLASS
4010812	6.5	80	230	180	10" SWAGED	FIBERGLASS
4010815	6.5	80	230	200	10" SWAGED	FIBERGLASS
4010817	6.5	80	230	250	10" SWAGED	FIBERGLASS
4010822	6.5	80	230	315	10" SWAGED	FIBERGLASS
4011010	6.5	100	230	125	10" SWAGED	FIBERGLASS
4011015	6.5	100	230	200	10" SWAGED	FIBERGLASS
4011017	6.5	100	230	250	10" SWAGED	FIBERGLASS
4011023	6.5	100	230	350	10" SWAGED	FIBERGLASS
4011316	6.5	130	230	220	10" SWAGED	FIBERGLASS
4011323	6.5	130	230	350	10" SWAGED	FIBERGLASS
4020404	8	40	230	100	10" CRIMPED	FIBERGLASS
4020410	8	40	230	160	10" CRIMPED	FIBERGLASS
4020415	8	40	230	200	10" CRIMPED	FIBERGLASS
4020417	8	40	230	250	10" CRIMPED	FIBERGLASS
4020505	8	50	230	125	10" CRIMPED	FIBERGLASS
4020515	8	50	230	200	10" CRIMPED	FIBERGLASS
4020517	8	50	230	250	10" CRIMPED	FIBERGLASS
4020522	8	50	230	315	10" CRIMPED	FIBERGLASS
4020605	8	60	230	125	10" CRIMPED	FIBERGLASS
4020615	8	60	230	200	10" CRIMPED	FIBERGLASS
4020617	8	60	230	250	10" CRIMPED	FIBERGLASS
4020618	8	60	230	280	10" CRIMPED	FIBERGLASS
4020815	8	80	230	200	10" CRIMPED	FIBERGLASS
4020822	8	80	230	315	10" CRIMPED	FIBERGLASS
4020826	8	80	230	400	10" CRIMPED	FIBERGLASS
4021015	8	100	230	200	10" CRIMPED	FIBERGLASS
4021017	8	100	230	250	10" CRIMPED	FIBERGLASS
4021022	8	100	230	315	10" CRIMPED	FIBERGLASS
4021026	8	100	230	400	10" CRIMPED	FIBERGLASS
4021317	8	130	230	250	10" CRIMPED	FIBERGLASS
4021322	8	130	230	315	10" CRIMPED	FIBERGLASS
4021326	8	130	230	400	10" CRIMPED	FIBERGLASS
4021615	8	160	230	200	10" CRIMPED	FIBERGLASS
4030404	10	40	230	100	10" CRIMPED	FIBERGLASS
4030405	10	40	230	125	10" CRIMPED	FIBERGLASS
4030415	10	40	230	200	10" CRIMPED	FIBERGLASS
4030422	10	40	230	315	10" CRIMPED	FIBERGLASS

*Available German Manufacture 2 – 4 Week Delivery.

*Subject to prior sales.

CE

Stock List: High-Watt Density Cartridge Heaters

PART #	DIAMETER	LENGTH	VOLTAGE	WATTAGE	LEAD CONNECTION	LEAD TYPE
4030504	10	50	230	100	10" CRIMPED	FIBERGLASS
4030510	10	50	230	160	10" CRIMPED	FIBERGLASS
4030515	10	50	230	200	10" CRIMPED	FIBERGLASS
4030517	10	50	230	250	10" CRIMPED	FIBERGLASS
4030526	10	50	230	400	10" CRIMPED	FIBERGLASS
4030605	10	60	230	125	10" CRIMPED	FIBERGLASS
4030610	10	60	230	160	10" CRIMPED	FIBERGLASS
4030612	10	60	230	180	10" CRIMPED	FIBERGLASS
4030617	10	60	230	250	10" CRIMPED	FIBERGLASS
4030622	10	60	230	315	10" CRIMPED	FIBERGLASS
4030626	10	60	230	400	10" CRIMPED	FIBERGLASS
4030630	10	60	230	500	10" CRIMPED	FIBERGLASS
4030810	10	80	230	160	10" CRIMPED	FIBERGLASS
4030817	10	80	230	250	10" CRIMPED	FIBERGLASS
4030822	10	80	230	315	10" CRIMPED	FIBERGLASS
4030826	10	80	230	400	10" CRIMPED	FIBERGLASS
4030830	10	80	230	500	10" CRIMPED	FIBERGLASS
4030835	10	80	230	630	10" CRIMPED	FIBERGLASS
4031016	10	100	230	220	10" CRIMPED	FIBERGLASS
4031017	10	100	230	250	10" CRIMPED	FIBERGLASS
4031022	10	100	230	315	10" CRIMPED	FIBERGLASS
4031023	10	100	230	350	10" CRIMPED	FIBERGLASS
4031026	10	100	230	400	10" CRIMPED	FIBERGLASS
4031030	10	100	230	500	10" CRIMPED	FIBERGLASS
4031035	10	100	230	630	10" CRIMPED	FIBERGLASS
4031044	10	100	230	850	10" CRIMPED	FIBERGLASS
4031322	10	130	230	315	10" CRIMPED	FIBERGLASS
4031326	10	130	230	400	10" CRIMPED	FIBERGLASS
4031330	10	130	230	500	10" CRIMPED	FIBERGLASS
4031335	10	130	230	630	10" CRIMPED	FIBERGLASS
4031343	10	130	230	800	10" CRIMPED	FIBERGLASS
4031626	10	160	230	400	10" CRIMPED	FIBERGLASS
4031635	10	160	230	630	10" CRIMPED	FIBERGLASS
4032026	10	200	230	400	10" CRIMPED	FIBERGLASS
4032035	10	200	230	630	10" CRIMPED	FIBERGLASS
4050417	12.5	40	230	250	10" CRIMPED	FIBERGLASS
4050426	12.5	40	230	400	10" CRIMPED	FIBERGLASS
4050504	12.5	50	230	100	10" CRIMPED	FIBERGLASS
4050515	12.5	50	230	200	10" CRIMPED	FIBERGLASS
4050615	12.5	60	230	200	10" CRIMPED	FIBERGLASS
4050617	12.5	60	230	250	10" CRIMPED	FIBERGLASS
4050622	12.5	60	230	315	10" CRIMPED	FIBERGLASS
4050817	12.5	80	230	250	10" CRIMPED	FIBERGLASS
4050822	12.5	80	230	315	10" CRIMPED	FIBERGLASS
4050830	12.5	80	230	500	10" CRIMPED	FIBERGLASS
4050835	12.5	80	230	630	10" CRIMPED	FIBERGLASS
4050843	12.5	80	230	800	10" CRIMPED	FIBERGLASS
4051026	12.5	100	230	400	10" CRIMPED	FIBERGLASS
4051030	12.5	100	230	500	10" CRIMPED	FIBERGLASS
4051035	12.5	100	230	630	10" CRIMPED	FIBERGLASS
4051043	12.5	100	230	800	10" CRIMPED	FIBERGLASS

*Available German Manufacture 2 – 4 Week Delivery.

*Subject to prior sales.

CE

Stock List: High-Watt Density Cartridge Heaters

PART #	DIAMETER	LENGTH	VOLTAGE	WATTAGE	LEAD CONNECTION	LEAD TYPE
4051326	12.5	130	230	400	10" CRIMPED	FIBERGLASS
4051330	12.5	130	230	500	10" CRIMPED	FIBERGLASS
4051335	12.5	130	230	630	10" CRIMPED	FIBERGLASS
4051343	12.5	130	230	800	10" CRIMPED	FIBERGLASS
4051352	12.5	130	230	1250	10" CRIMPED	FIBERGLASS
4051630	12.5	160	230	500	10" CRIMPED	FIBERGLASS
4051635	12.5	160	230	630	10" CRIMPED	FIBERGLASS
4051643	12.5	160	230	800	10" CRIMPED	FIBERGLASS
4051836	12.5	180	230	670	10" CRIMPED	FIBERGLASS
4051850	12.5	180	230	1000	10" CRIMPED	FIBERGLASS
4052035	12.5	200	230	630	10" CRIMPED	FIBERGLASS
4052043	12.5	200	230	800	10" CRIMPED	FIBERGLASS
4052047	12.5	200	230	900	10" CRIMPED	FIBERGLASS
4052543	12.5	250	230	800	10" CRIMPED	FIBERGLASS
4052547	12.5	250	230	900	10" CRIMPED	FIBERGLASS
4060404	16	40	230	100	10" CRIMPED	FIBERGLASS
4060417	16	40	230	250	10" CRIMPED	FIBERGLASS
4060426	16	40	230	400	10" CRIMPED	FIBERGLASS
4060510	16	50	230	160	10" CRIMPED	FIBERGLASS
4060517	16	50	230	250	10" CRIMPED	FIBERGLASS
4060526	16	50	230	400	10" CRIMPED	FIBERGLASS
4060615	16	60	230	200	10" CRIMPED	FIBERGLASS
4060622	16	60	230	315	10" CRIMPED	FIBERGLASS
4060626	16	60	230	400	10" CRIMPED	FIBERGLASS
4060635	16	60	230	630	10" CRIMPED	FIBERGLASS
4060826	16	80	230	400	10" CRIMPED	FIBERGLASS
4060830	16	80	230	500	10" CRIMPED	FIBERGLASS
4060835	16	80	230	630	10" CRIMPED	FIBERGLASS
4060843	16	80	230	800	10" CRIMPED	FIBERGLASS
4061026	16	100	230	400	10" CRIMPED	FIBERGLASS
4061030	16	100	230	500	10" CRIMPED	FIBERGLASS
4061035	16	100	230	630	10" CRIMPED	FIBERGLASS
4061043	16	100	230	800	10" CRIMPED	FIBERGLASS
4061050	16	100	230	1000	10" CRIMPED	FIBERGLASS
4061052	16	100	230	1250	10" CRIMPED	FIBERGLASS
4061330	16	130	230	500	10" CRIMPED	FIBERGLASS
4061335	16	130	230	630	10" CRIMPED	FIBERGLASS
4061339	16	130	230	700	10" CRIMPED	FIBERGLASS
4061343	16	130	230	800	10" CRIMPED	FIBERGLASS
4061347	16	130	230	1000	10" CRIMPED	FIBERGLASS
4061635	16	160	230	630	10" CRIMPED	FIBERGLASS
4061643	16	160	230	800	10" CRIMPED	FIBERGLASS
4061650	16	160	230	1000	10" CRIMPED	FIBERGLASS
4061652	16	160	230	1250	10" CRIMPED	FIBERGLASS
4061844	16	180	230	850	10" CRIMPED	FIBERGLASS
4061852	16	180	230	1250	10" CRIMPED	FIBERGLASS
4061856	16	180	230	1800	10" CRIMPED	FIBERGLASS

*Available German Manufacture 2 – 4 Week Delivery.

*Subject to prior sales.

Stock List: High-Watt Density Cartridge Heaters

PART #	DIAMETER	LENGTH	VOLTAGE	WATTAGE	LEAD CONNECTION	LEAD TYPE
4062030	16	200	230	500	10" CRIMPED	FIBERGLASS
4062043	16	200	230	800	10" CRIMPED	FIBERGLASS
4062050	16	200	230	1000	10" CRIMPED	FIBERGLASS
4062052	16	200	230	1250	10" CRIMPED	FIBERGLASS
4062061	16	200	230	2000	10" CRIMPED	FIBERGLASS
4062550	16	250	230	1000	10" CRIMPED	FIBERGLASS
4062552	16	250	230	1250	10" CRIMPED	FIBERGLASS
4062555	16	250	230	1600	10" CRIMPED	FIBERGLASS
4063050	16	300	230	1000	10" CRIMPED	FIBERGLASS
4063052	16	300	230	1250	10" CRIMPED	FIBERGLASS
4063054	16	300	230	1500	10" CRIMPED	FIBERGLASS
4063056	16	300	230	1800	10" CRIMPED	FIBERGLASS
4070622	20	60	230	315	10" CRIMPED	FIBERGLASS
4070643	20	60	230	800	10" CRIMPED	FIBERGLASS
4070823	20	80	230	350	10" CRIMPED	FIBERGLASS
4070843	20	80	230	800	10" CRIMPED	FIBERGLASS
4070850	20	80	230	1000	10" CRIMPED	FIBERGLASS
4071043	20	100	230	800	10" CRIMPED	FIBERGLASS
4071050	20	100	230	1000	10" CRIMPED	FIBERGLASS
4071055	20	100	230	1600	10" CRIMPED	FIBERGLASS
4071335	20	130	230	630	10" CRIMPED	FIBERGLASS
4071347	20	130	230	900	10" CRIMPED	FIBERGLASS
4071352	20	130	230	1250	10" CRIMPED	FIBERGLASS
4071353	20	130	230	1400	10" CRIMPED	FIBERGLASS
4071643	20	160	230	800	10" CRIMPED	FIBERGLASS
4071650	20	160	230	1000	10" CRIMPED	FIBERGLASS
4071652	20	160	230	1250	10" CRIMPED	FIBERGLASS
4071656	20	160	230	1800	10" CRIMPED	FIBERGLASS
4072050	20	200	230	1000	10" CRIMPED	FIBERGLASS
4072055	20	200	230	1600	10" CRIMPED	FIBERGLASS
4072552	20	250	230	1250	10" CRIMPED	FIBERGLASS
4072561	20	250	230	2000	10" CRIMPED	FIBERGLASS
4073055	20	300	230	1600	10" CRIMPED	FIBERGLASS
4073062	20	300	230	2200	10" CRIMPED	FIBERGLASS
4110305	1/4"	1.5"	230	125	10" CRIMPED	FIBERGLASS
4110311	1/4"	1.5"	230	175	10" CRIMPED	FIBERGLASS
4110315	1/4"	1.5"	230	200	10" CRIMPED	FIBERGLASS
4110505	1/4"	2"	230	125	10" CRIMPED	FIBERGLASS
4110509	1/4"	2"	230	150	10" CRIMPED	FIBERGLASS
4110515	1/4"	2"	230	200	10" CRIMPED	FIBERGLASS
4110517	1/4"	2"	230	250	10" CRIMPED	FIBERGLASS
4110605	1/4"	2.5"	230	125	10" CRIMPED	FIBERGLASS
4110617	1/4"	2.5"	230	250	10" CRIMPED	FIBERGLASS
4110715	1/4"	3"	230	200	10" CRIMPED	FIBERGLASS
4110721	1/4"	3"	230	300	10" CRIMPED	FIBERGLASS
4110805	1/4"	3.25"	230	125	10" CRIMPED	FIBERGLASS
4110823	1/4"	3.25"	230	350	10" CRIMPED	FIBERGLASS
4111010	1/4"	4"	230	160	10" CRIMPED	FIBERGLASS
4111016	1/4"	4"	230	220	10" CRIMPED	FIBERGLASS
4111023	1/4"	4"	230	350	10" CRIMPED	FIBERGLASS

*Available German Manufacture 2 – 4 Week Delivery.

*Subject to prior sales.

Stock List: High-Watt Density Cartridge Heaters

PART #	DIAMETER	LENGTH	VOLTAGE	WATTAGE	LEAD CONNECTION	LEAD TYPE
4130311	3/8"	1.5"	230	175	10" CRIMPED	FIBERGLASS
4130315	3/8"	1.5"	230	200	10" CRIMPED	FIBERGLASS
4130317	3/8"	1.5"	230	250	10" CRIMPED	FIBERGLASS
4130504	3/8"	2"	230	100	10" CRIMPED	FIBERGLASS
4130510	3/8"	2"	230	160	10" CRIMPED	FIBERGLASS
4130517	3/8"	2"	230	250	10" CRIMPED	FIBERGLASS
4130522	3/8"	2"	230	315	10" CRIMPED	FIBERGLASS
4130526	3/8"	2"	230	400	10" CRIMPED	FIBERGLASS
4130612	3/8"	2.5"	230	180	10" CRIMPED	FIBERGLASS
4130617	3/8"	2.5"	230	250	10" CRIMPED	FIBERGLASS
4130626	3/8"	2.5"	230	400	10" CRIMPED	FIBERGLASS
4130630	3/8"	2.5"	230	500	10" CRIMPED	FIBERGLASS
4130717	3/8"	3"	230	250	10" CRIMPED	FIBERGLASS
4130726	3/8"	3"	230	400	10" CRIMPED	FIBERGLASS
4130730	3/8"	3"	230	500	10" CRIMPED	FIBERGLASS
4130734	3/8"	3"	230	600	10" CRIMPED	FIBERGLASS
4130810	3/8"	3.25"	230	160	10" CRIMPED	FIBERGLASS
4130826	3/8"	3.25"	230	400	10" CRIMPED	FIBERGLASS
4131017	3/8"	4"	230	250	10" CRIMPED	FIBERGLASS
4131021	3/8"	4"	230	300	10" CRIMPED	FIBERGLASS
4131023	3/8"	4"	230	350	10" CRIMPED	FIBERGLASS
4131030	3/8"	4"	230	500	10" CRIMPED	FIBERGLASS
4131221	3/8"	5"	230	300	10" CRIMPED	FIBERGLASS
4131230	3/8"	5"	230	500	10" CRIMPED	FIBERGLASS
4131326	3/8"	5.25"	230	400	10" CRIMPED	FIBERGLASS
4131330	3/8"	5.25"	230	500	10" CRIMPED	FIBERGLASS
4131530	3/8"	6"	230	500	10" CRIMPED	FIBERGLASS
4131540	3/8"	6"	230	750	10" CRIMPED	FIBERGLASS
4131626	3/8"	6.5"	230	400	10" CRIMPED	FIBERGLASS
4131635	3/8"	6.5"	230	630	10" CRIMPED	FIBERGLASS
4150310	1/2"	1.5"	230	160	10" CRIMPED	FIBERGLASS
4150315	1/2"	1.5"	230	200	10" CRIMPED	FIBERGLASS
4150317	1/2"	1.5"	230	250	10" CRIMPED	FIBERGLASS
4150504	1/2"	2"	230	100	10" CRIMPED	FIBERGLASS
4150515	1/2"	2"	230	200	10" CRIMPED	FIBERGLASS
4150521	1/2"	2"	230	300	10" CRIMPED	FIBERGLASS
4150522	1/2"	2"	230	315	10" CRIMPED	FIBERGLASS
4150526	1/2"	2"	230	400	10" CRIMPED	FIBERGLASS
4150530	1/2"	2"	230	500	10" CRIMPED	FIBERGLASS
4150609	1/2"	2.5"	230	150	10" CRIMPED	FIBERGLASS
4150615	1/2"	2.5"	230	200	10" CRIMPED	FIBERGLASS
4150617	1/2"	2.5"	230	250	10" CRIMPED	FIBERGLASS
4150622	1/2"	2.5"	230	315	10" CRIMPED	FIBERGLASS
4150626	1/2"	2.5"	230	400	10" CRIMPED	FIBERGLASS
4150630	1/2"	2.5"	230	500	10" CRIMPED	FIBERGLASS
4150715	1/2"	3"	230	200	10" CRIMPED	FIBERGLASS
4150721	1/2"	3"	230	300	10" CRIMPED	FIBERGLASS
4150726	1/2"	3"	230	400	10" CRIMPED	FIBERGLASS
4150730	1/2"	3"	230	500	10" CRIMPED	FIBERGLASS
4150734	1/2"	3"	230	600	10" CRIMPED	FIBERGLASS
4150740	1/2"	3"	230	750	10" CRIMPED	FIBERGLASS

*Available German Manufacture 2 – 4 Week Delivery.

*Subject to prior sales.

Stock List: High-Watt Density Cartridge Heaters

PART #	DIAMETER	LENGTH	VOLTAGE	WATTAGE	LEAD CONNECTION	LEAD TYPE
4150815	1/2"	3.25"	230	200	10" CRIMPED	FIBERGLASS
4150822	1/2"	3.25"	230	315	10" CRIMPED	FIBERGLASS
4150830	1/2"	3.25"	230	500	10" CRIMPED	FIBERGLASS
4150835	1/2"	3.25"	230	630	10" CRIMPED	FIBERGLASS
4150843	1/2"	3.25"	230	800	10" CRIMPED	FIBERGLASS
4151017	1/2"	4"	230	250	10" CRIMPED	FIBERGLASS
4151026	1/2"	4"	230	400	10" CRIMPED	FIBERGLASS
4151030	1/2"	4"	230	500	10" CRIMPED	FIBERGLASS
4151035	1/2"	4"	230	630	10" CRIMPED	FIBERGLASS
4151040	1/2"	4"	230	750	10" CRIMPED	FIBERGLASS
4151043	1/2"	4"	230	800	10" CRIMPED	FIBERGLASS
4151050	1/2"	4"	230	1000	10" CRIMPED	FIBERGLASS
4151226	1/2"	5"	230	400	10" CRIMPED	FIBERGLASS
4151230	1/2"	5"	230	500	10" CRIMPED	FIBERGLASS
4151240	1/2"	5"	230	750	10" CRIMPED	FIBERGLASS
4151247	1/2"	5"	230	900	10" CRIMPED	FIBERGLASS
4151326	1/2"	5.25"	230	400	10" CRIMPED	FIBERGLASS
4151335	1/2"	5.25"	230	630	10" CRIMPED	FIBERGLASS
4151530	1/2"	6"	230	500	10" CRIMPED	FIBERGLASS
4151534	1/2"	6"	230	600	10" CRIMPED	FIBERGLASS
4151540	1/2"	6"	230	750	10" CRIMPED	FIBERGLASS
4151550	1/2"	6"	230	1000	10" CRIMPED	FIBERGLASS
4151630	1/2"	6.5"	230	500	10" CRIMPED	FIBERGLASS
4151643	1/2"	6.5"	230	800	10" CRIMPED	FIBERGLASS
4151652	1/2"	6.5"	230	1250	10" CRIMPED	FIBERGLASS
4151734	1/2"	7"	230	600	10" CRIMPED	FIBERGLASS
4152035	1/2"	8"	230	630	10" CRIMPED	FIBERGLASS
4152047	1/2"	8"	230	900	10" CRIMPED	FIBERGLASS
4152050	1/2"	8"	230	1000	10" CRIMPED	FIBERGLASS
4152054	1/2"	8"	230	1500	10" CRIMPED	FIBERGLASS
4152554	1/2"	10"	230	1500	10" CRIMPED	FIBERGLASS
4153054	1/2"	12"	230	1500	10" CRIMPED	FIBERGLASS
4160317	5/8"	1.5"	230	250	10" CRIMPED	FIBERGLASS
4160322	5/8"	1.5"	230	315	10" CRIMPED	FIBERGLASS
4160510	5/8"	2"	230	160	10" CRIMPED	FIBERGLASS
4160526	5/8"	2"	230	400	10" CRIMPED	FIBERGLASS
4160530	5/8"	2"	230	500	10" CRIMPED	FIBERGLASS
4160617	5/8"	2.5"	230	250	10" CRIMPED	FIBERGLASS
4160626	5/8"	2.5"	230	400	10" CRIMPED	FIBERGLASS
4160730	5/8"	3"	230	500	10" CRIMPED	FIBERGLASS
4160740	5/8"	3"	230	750	10" CRIMPED	FIBERGLASS
4160750	5/8"	3"	230	1000	10" CRIMPED	FIBERGLASS
4160826	5/8"	3.25"	230	400	10" CRIMPED	FIBERGLASS
4160826	5/8"	3.25"	230	630	10" CRIMPED	FIBERGLASS
4161030	5/8"	4"	230	500	10" CRIMPED	FIBERGLASS
4161034	5/8"	4"	230	600	10" CRIMPED	FIBERGLASS
4161040	5/8"	4"	230	750	10" CRIMPED	FIBERGLASS
4161230	5/8"	5"	230	500	10" CRIMPED	FIBERGLASS
4161240	5/8"	5"	230	750	10" CRIMPED	FIBERGLASS
4161250	5/8"	5"	230	1000	10" CRIMPED	FIBERGLASS
4161330	5/8"	5.25"	230	500	10" CRIMPED	FIBERGLASS
4161330	5/8"	5.25"	230	1100	10" CRIMPED	FIBERGLASS

*Available German Manufacture 2 – 4 Week Delivery.

*Subject to prior sales.

HJ or HK HIGH-WATT DENSITY CARTRIDGE HEATER With Thermocouple

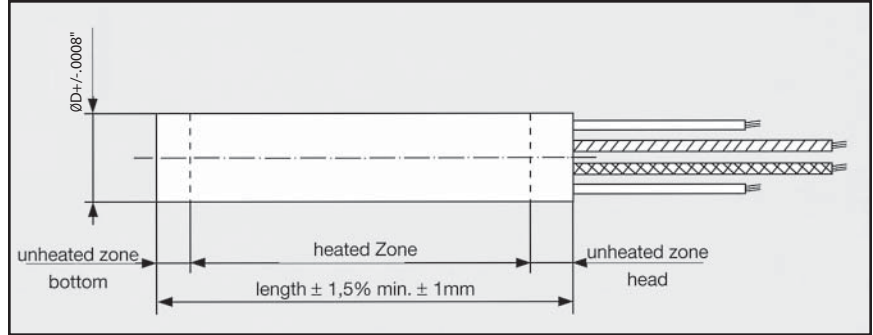

DIAMETERS AVAILABLE

IMPERIAL	1/4"	3/8"	5/16"	1/2"	5/8"	11/16"	3/4"	1"
METRIC	6.5	8	9.5	10	12	12.5	15	16
	18	19	20	25				

*Special diameter available, consult factory

Standard details

Thermocouple Type J (HJ – FeCuNi to 1382° F operating temperature)

Thermocouple Type K (HK – NiCrNi to 2282° F operating temperature)

Thermocouple ungrounded/grounded

Thermocouple location disc end or center

Flat bottom

Swaged or crimped leads

Order Detail (Example)

Type: HJ
 Thermocouple: Type J
 Diameter: 10mm
 Length: 80mm
 Wattage: 250 watt
 Voltage: 230 volt
 Lead Connection: Swaged
 Lead Length: 40" Fiberglass
 Lead Option: Optional

Options:

1. Lead types and protection
2. Lead exit styles (right angle block, right angle elbow, and right angle exit)
3. RTD 100 Ohm optional (PT100) – consult factory for availability
4. See options page 24-27

Stock List: High-Watt Density Cartridge Heaters with Type J Thermocouple

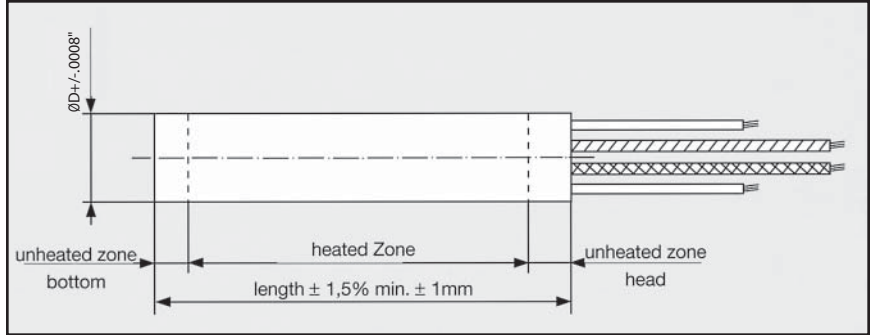
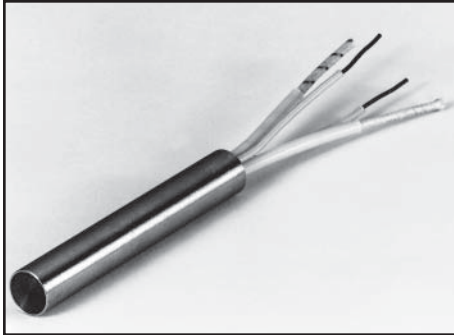

PART #	DIAM.	LENGTH IN.	LENGTH MM	VOLTAGE	WATTAGE	LEAD LENGTH	CONNECTION
1258	1/4"	4.0	101.6	240	350	10"	SWAGED
1259	1/4"	1.5	38.1	240	175	10"	SWAGED
1260	1/4"	2.0	50.8	240	200	10"	SWAGED
1261	1/4"	2.5	63.5	240	250	10"	SWAGED
1262	1/4"	3.0	76.2	230	300	10"	SWAGED
1263	1/4"	3.0	76.2	240	150	10"	SWAGED
1265	1/4"	3.8	95.3	240	220	10"	SWAGED
1267	1/4"	4.0	101.6	240	350	10"	SWAGED
1269	1/4"	4.8	120.7	240	275	10"	SWAGED
1270	1/4"	5.8	146.1	240	350	10"	SWAGED
12713/8"	1.5	38.1	240	200	10"	SWAGED	
12723/8"	2.0	50.8	230	250	10"	SWAGED	
12733/8"	2.5	63.5	230	250	10"	SWAGED	
12743/8"	3.0	76.2	240	250	10"	SWAGED	
1276	3/8"	3.5	88.9	240	250	10"	SWAGED
12773/8"	4.0	101.6	230	350	10"	SWAGED	
1278	3/8"	4.0	101.6	240	250	10"	SWAGED
12803/8"	6.0	152.4	230	500	10"	SWAGED	
1283	1/2"	2.5	63.5	240	250	10"	SWAGED
1284	1/2"	4.0	101.6	230	500	10"	SWAGED
1285	1/2"	5.0	127.0	240	500	10"	SWAGED

*Same day shipping orders must be received by 1:00 PM to meet carrier deadlines.

*Subject to prior sales.

Stock List: High-Watt Density Cartridge Heaters with Type J Thermocouple

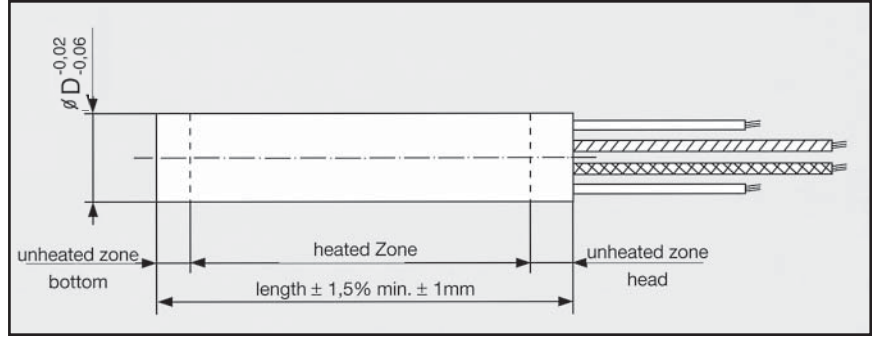

PART #	DIAMETER	LENGTH	VOLTAGE	WATTAGE	LEAD CONNECTION	LEAD TYPE
5210404	6.5	40	230	100	10" SWAGED	FIBERGLASS
5210411	6.5	40	230	175	10" SWAGED	FIBERGLASS
5210415	6.5	40	230	200	10" SWAGED	FIBERGLASS
5210515	6.5	50	230	200	10" SWAGED	FIBERGLASS
5210615	6.5	60	230	200	10" SWAGED	FIBERGLASS
5210617	6.5	60	230	250	10" SWAGED	FIBERGLASS
5211023	6.5	100	230	350	10" SWAGED	FIBERGLASS
5220404	8	40	230	100	10" CRIMPED	FIBERGLASS
5220517	8	50	230	250	10" CRIMPED	FIBERGLASS
5220617	8	60	230	250	10" CRIMPED	FIBERGLASS
5220822	8	80	230	315	10" CRIMPED	FIBERGLASS
5221022	8	100	230	315	10" CRIMPED	FIBERGLASS
5221326	8	130	230	400	10" CRIMPED	FIBERGLASS
5230415	10	40	230	200	10" CRIMPED	FIBERGLASS
5230517	10	50	230	250	10" CRIMPED	FIBERGLASS
5230617	10	60	230	250	10" CRIMPED	FIBERGLASS
5230626	10	60	230	400	10" CRIMPED	FIBERGLASS
5230817	10	80	230	250	10" CRIMPED	FIBERGLASS
5230822	10	80	230	315	10" CRIMPED	FIBERGLASS
5231023	10	100	230	350	10" CRIMPED	FIBERGLASS
5231626	10	160	230	400	10" CRIMPED	FIBERGLASS
5231632	10	160	230	575	10" CRIMPED	FIBERGLASS
5231635	10	160	230	630	10" CRIMPED	FIBERGLASS
5250622	12.5	60	230	315	10" CRIMPED	FIBERGLASS
5250626	12.5	60	230	400	10" CRIMPED	FIBERGLASS
5251030	12.5	100	230	500	10" CRIMPED	FIBERGLASS
5251643	12.5	160	230	800	10" CRIMPED	FIBERGLASS
5420506	8	50	230	130	10" CRIMPED	FIBERGLASS
5420611	8	65	230	170	10" CRIMPED	FIBERGLASS
5420868	8	85	230	195	10" CRIMPED	FIBERGLASS
5430611	9.5	68	230	175	10" CRIMPED	FIBERGLASS
5340816	9.5	85	230	220	10" CRIMPED	FIBERGLASS
5431118	9.5	112	230	285	10" CRIMPED	FIBERGLASS
5431323	9.5	137	230	355	10" CRIMPED	FIBERGLASS

*Available German Manufacture 2 – 4 Week Delivery.

*Subject to prior sales.

HIGH WATT DENSITY CARTRIDGE HEATER

HI – 4mm Diameter

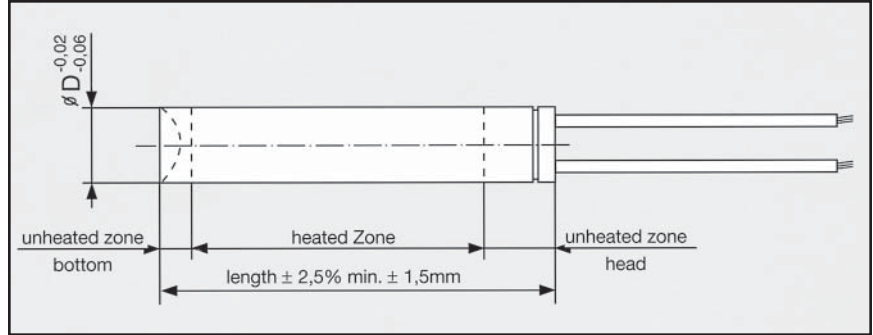

Standard details

Diameter 4mm

Connection of swaged teflon insulated leads

Gas proof welded heater tip

Teflon seal at heater head

Order Details (Example)

Type:	HI 4mm diameter
Thermocouple Type & Location:	Type J at tip
Length:	60mm
Wattage:	100
Voltage:	230
Lead Type:	500mm swaged Teflon leads

Options:

1. Thermocouple: Type J or Type K
2. Measuring point at tip or within heated zone (always ungrounded)
3. Lead length
4. Protective sleeving (externally crimped on)

Reference:

1. Note maximum operating temperature of 900° F.
2. To increase tool temperature, the connection head should be positioned a maximum of 11mm outside the tool or a counter bore hole depth of 11mm and a diameter of 5mm should be constructed if the connection head is placed inside the tool.

HIGH WATT DENSITY CARTRIDGE HEATER with Integral Cutting Blade for cutting foils with plastic textile materials

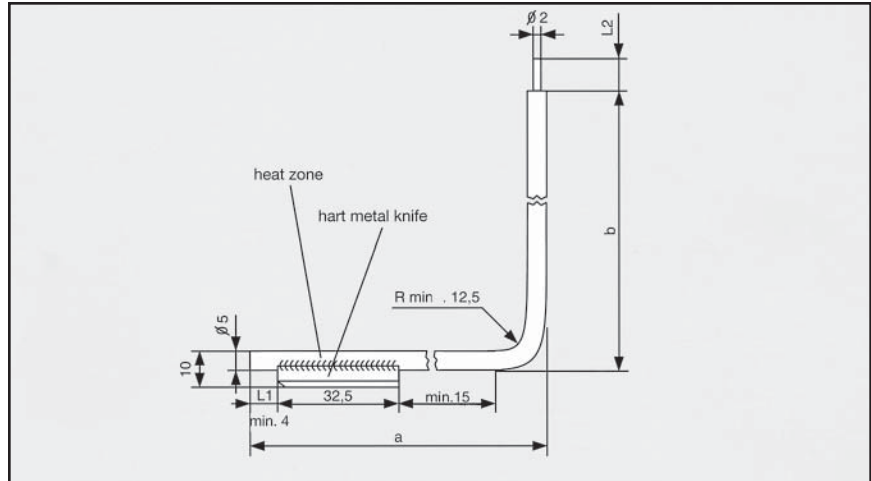

Standard details:

Cartridge heater diameter 5.0mm or 6.5mm

Cutting blade made of resistant tungsten carbide

Solid connection pin

12 Volt low safety voltage/maximum 24v

Negative return on sheath

Order Details (Example)

Type:	High-Watt Density Cartridge Heater with cutting blade Formed with 90°
Diameter:	5mm
Length a:	70mm
Length b:	80mm
L1:	6mm
L2:	40mm solid connection pin
Wattage:	90
Voltage:	12
On 6.5mm:	Lead connection, type and option

Options:

1. May be supplied formed or straight
2. Up to a maximum of 24 Volt low safety voltage
3. Different wattage and voltage (consult factory)
4. See options page 24-27

LI HIGHLY COMPRESSED CARTRIDGE HEATER

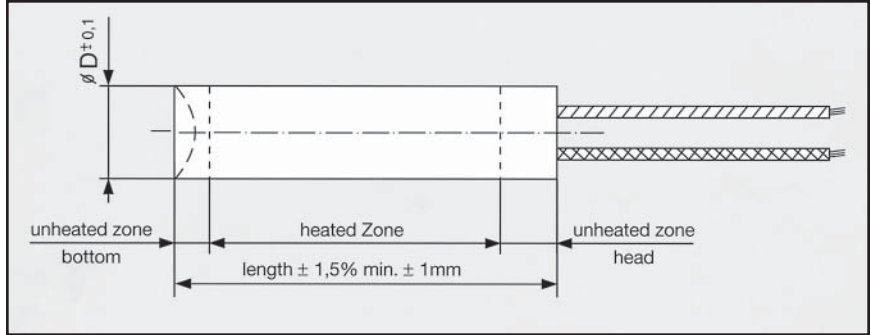

DIAMETERS AVAILABLE

IMPERIAL	1/4"	3/8"	5/16"	1/2"	5/8"	11/16"	3/4"	1"
METRIC	6.5	8	9.5	10	12	12.5	15	16
	18	19	20	25				

*Special diameter available, consult factory

Standard details

Diameters available - see table above

Lengths available - from 4" (stock)

Wattage - 80 W/in² maximum watt density (with centerless ground surface)

Lead connection - swaged or crimped

Lead length

For special sizes, lengths and wattages, consult factory. Delivery 2 - 3 weeks.

Order Details (Example)

Type:	LI
Diameter:	1/2"
Length:	18"
Wattage:	350
Voltage:	230
Lead length, type & connection:	Post terminal - one at each end (SBE)

Options:

1. Lead connection, lead type and lead protection
2. Different diameters and lengths (other than stock range)
3. See options page 24-27

Stock List: Medium-Watt Density Cartridge Heaters

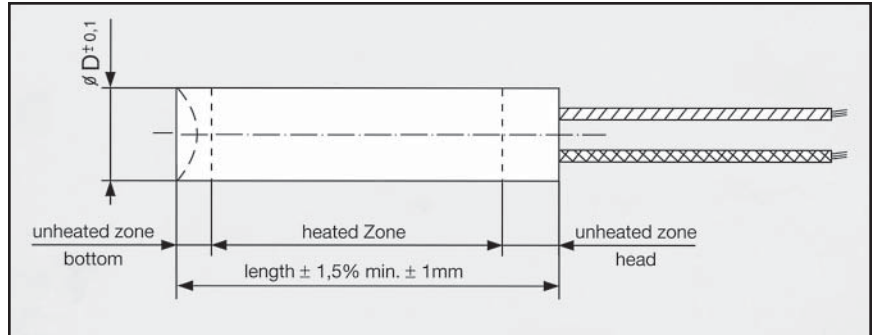
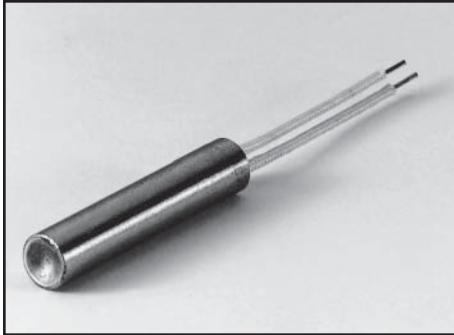

PART #	DIAMETER	LENGTH	VOLTAGE	WATTAGE	LEAD CONNECTION	LEAD TYPE
6031004	10	100	230	100	10" CRIMPED	FIBERGLASS
6031005	10	100	230	125	10" CRIMPED	FIBERGLASS
6031010	10	100	230	160	10" CRIMPED	FIBERGLASS
6031315	10	130	230	200	10" CRIMPED	FIBERGLASS
6031317	10	130	230	250	10" CRIMPED	FIBERGLASS
6031617	10	160	230	250	10" CRIMPED	FIBERGLASS
6031622	10	160	230	315	10" CRIMPED	FIBERGLASS
6032021	10	200	230	300	10" CRIMPED	FIBERGLASS
6032023	10	200	230	350	10" CRIMPED	FIBERGLASS
6051010	12.5	100	230	160	10" CRIMPED	FIBERGLASS
6051015	12.5	100	230	200	10" CRIMPED	FIBERGLASS
6051316	12.5	130	230	220	10" CRIMPED	FIBERGLASS
6051322	12.5	130	230	315	10" CRIMPED	FIBERGLASS
6051622	12.5	160	230	315	10" CRIMPED	FIBERGLASS
6051626	12.5	160	230	400	10" CRIMPED	FIBERGLASS
6052026	12.5	200	230	400	10" CRIMPED	FIBERGLASS
6052030	12.5	200	230	500	10" CRIMPED	FIBERGLASS
6052530	12.5	250	230	500	10" CRIMPED	FIBERGLASS
6052534	12.5	250	230	600	10" CRIMPED	FIBERGLASS
6053034	12.5	300	230	600	10" CRIMPED	FIBERGLASS
6053040	12.5	300	230	750	10" CRIMPED	FIBERGLASS
6061015	16	100	230	200	10" CRIMPED	FIBERGLASS
6061018	16	100	230	280	10" CRIMPED	FIBERGLASS
6061318	16	130	230	280	10" CRIMPED	FIBERGLASS
6061323	16	130	230	350	10" CRIMPED	FIBERGLASS
6062539	16	250	230	700	10" CRIMPED	FIBERGLASS
6063039	16	300	230	700	10" CRIMPED	FIBERGLASS
6071017	20	100	230	250	10" CRIMPED	FIBERGLASS
6073050	20	300	230	1000	10" CRIMPED	FIBERGLASS
6073052	20	300	230	1250	10" CRIMPED	FIBERGLASS

*Available German Manufacture 2 – 4 Week Delivery.

*Subject to prior sales.

CE

NP

LOW-WATT DENSITY CARTRIDGE HEATER

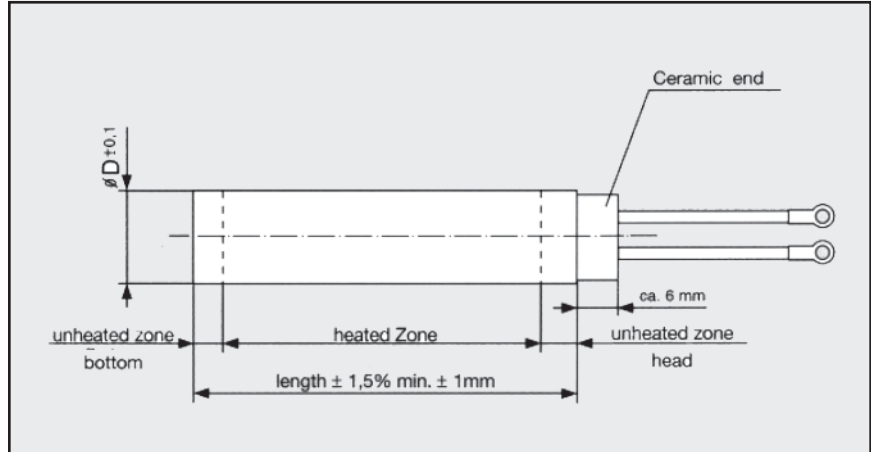

DIAMETERS AVAILABLE

METRIC	8	11	12	13	14	15	16	16.5
	18	19.5	22	23	25	26	35	36
	38	39	40					

*Special diameter available, consult factory

Standard details:

Diameters available - see table

Lengths from 65mm

Choice of sheath material: steel, brass or stainless steel depending on diameter

Lead connection standard 200mm fiberglass insulated leads

Heater tip rolled to hold in place

Order Details (Example)

Diameter from 8.0 to 40.0mm:	8.0
Length from 65mm:	1000mm
Wattage:	120w
Voltage:	120v
Lead connection:	254.0mm Swaged
Lead type:	Fiberglass
Lead option:	Optional

Options:

1. Different length and diameter
2. Low voltage (12 or 24 Volt) possible
3. Choice of lead lengths
4. Heater end disc soldered or welded (standard rolled end)
5. Wattage distribution
6. See options page 24-27

*Available German Manufacture 2 – 4 Week Delivery.

*Subject to prior sales.

LEAD OPTIONS – HI, HJ, HK

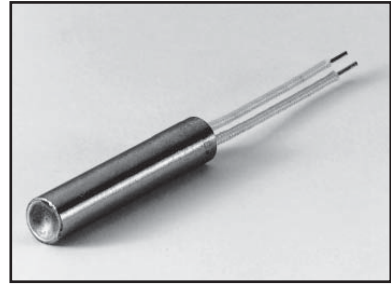
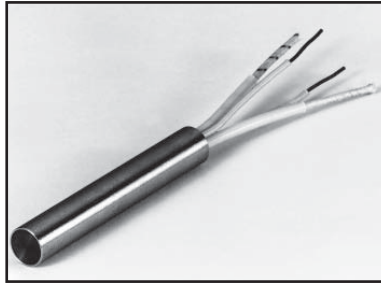
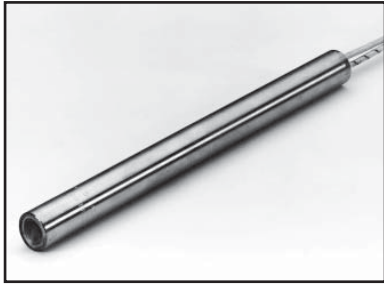

Additional Options

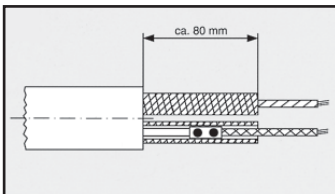

Crimped outside heater

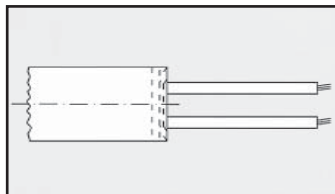

Silicone insulated leads
to 356° F

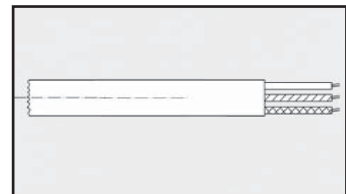

Groundwire (not available
with thermocouple)

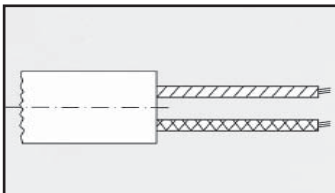

Swaged/internal fiberglass
leads to 482° F

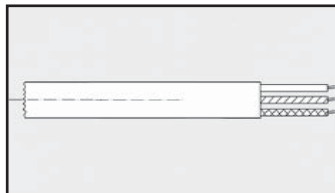

Silicone cable
to 500° F

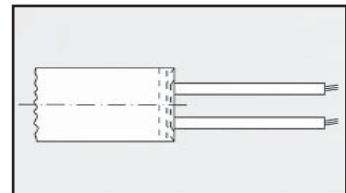

Teflon insulated leads
to 470° F

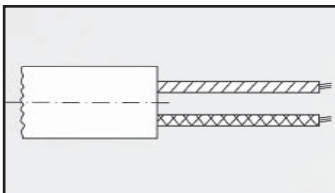

High temperature option
to 1082° F

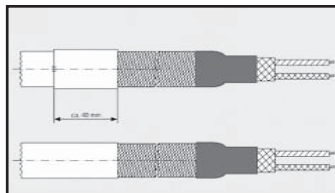

Braided metal

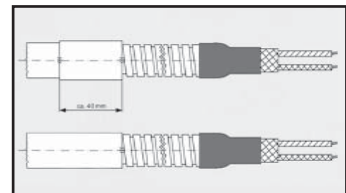

Armor cable

CONNECTION OPTIONS

Right angle elbow

Options

- with stress relief tube
- with braided metal sleeving
- with armor cable
- with fiberglass sleeving
- sealed against the introduction of moisture (maximum of 356° F)

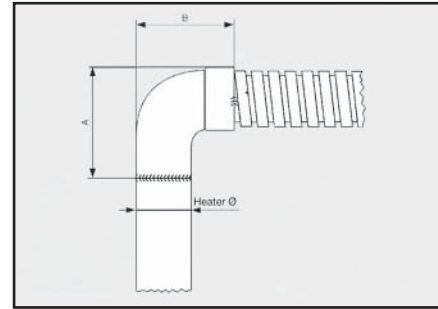

	Heater Diameter					
Dimension	1/4" or 6.35mm	5/16" or 7.9mm	3/8" or 9.5mm	1/2" or 12.5mm	5/8" or 15.8mm	3/4" or 19mm
A	.43"	.43"	.55"	.62"	.82"	.98"
B	.47"	.55"	.66"	.74"	.94"	1.10"

Options

- with stress relief tube
- with braided metal sleeving
- with armor cable
- with fiberglass sleeving
- sealed against the introduction of moisture (maximum of 356° F)

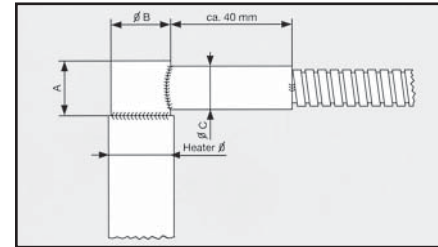

	Heater Diameter					
Dimension	1/4" or 6.35mm	5/16" or 7.9mm	3/8" or 9.5mm	1/2" or 12.5mm	5/8" or 15.8mm	3/4" or 19mm
A	.43"	.43"	.55"	.62"	.82"	.98"
B	.47"	.55"	.66"	.74"	.94"	1.10"

Right angle block

Options

- with stress relief tube
- with armor cable
- with braided metal sleeving
- with fiberglass sleeving
- sealed against the introduction of moisture (maximum 356° F)

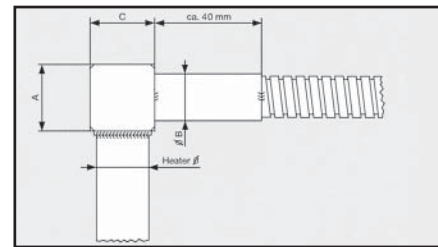

CONNECTION OPTIONS

Description

Flange

- stainless steel
- may be fastened anywhere within the unheated zone

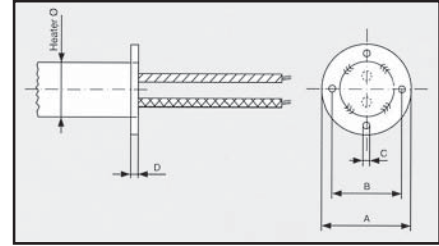
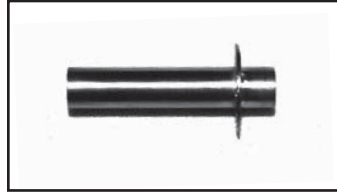

	Heater Diameter						
Dimension	1/4" or 6.35mm	8mm	3/8" or 9.5mm	1/2" or 12.5mm	5/8" or 15.8mm	3/4" or 19mm	20mm
A	.70"	.70"	1.06"	1.06"	1.29"	1.29"	1.29"
B	.51"	.51"	.78"	.78"	1"	1"	1"
C	.087"	.087"	.125"	.125"	.125"	.125"	.125"

NPT

- stainless steel

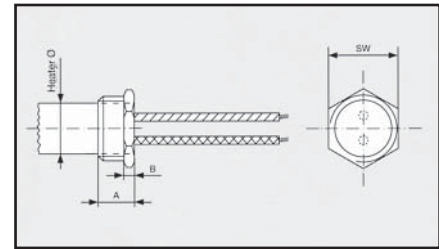
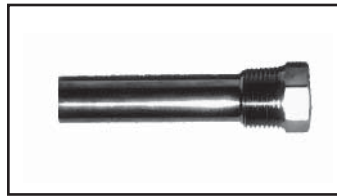

	Heater Diameter						
Dimension	1/4" or 6.35mm	8mm	3/8" or 9.5mm	1/2" or 12.5mm	5/8" or 15.8mm	3/4" or 19mm	20mm
A	.70"	.70"	1.06"	1.06"	1.29"	1.29"	1.29"
B	.51"	.51"	.78"	.78"	1"	1"	1"
C	.087"	.087"	.125"	.125"	.125"	.125"	.125"

ADDITIONAL OPTIONS

Double NPT



Knock Out Tab



Screw Terminals Both Ends (SBE)



Screw Terminals One End (SOE)

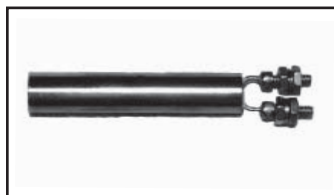

CARTRIDGE HEATER TECHNICAL HEATER

	HI / HJ / HK	HI-4mm	HI w/knife	LI	NP
heater sheath	CrNi steel	CrNi-steel	Incoloy	CrNi-steel	steel/stainless steel/brass
insulation material	highly compressed MgO	highly compressed MgO	highly compressed MgO	highly compressed MgO	MgO
heating wire	NiCr 8020	NiCr 8020	NiCr 8020	NiCr 8020	NiCr 8020
maximum temperature on heater sheath	1382° F	500° F	1742° F	1382° F	Steel 482° F/brass F/brass 356° F/stainless steel 752° F
high voltage stability (cold)	500V-AC nominal voltage <= 24V 1500V-AC nominal voltage > 24Volt >1500 V-AC on request	500V-AC nominal voltage <= 24 Volt 800 V-AC nominal voltage >24 Volt		500V-AC nominal voltage <=24V AC nominal voltage > 24Volt >1500 V-AC on request	500V-AC nominal voltage <=24V 1500V-AC nominal voltage > 24Volt >1500 V-AC on request
insulation resistance (cold)	min. 5M ohms at 500 V-DC > 5M ohms on request	min. 5M ohms at 500 V-DC > 5M ohms on request		min. 5M ohms at 500 V-DC > 5M ohms on request	min. 5M ohms at 500 V-DC > 5M ohms on request
discharge current (cold)	max 0.5mA at 253 V-DC > 5M ohms on request	max 0.5mA at 253 V-DC > 5M ohms on request		max 0.5mA at 253 V-DC > 5M ohms on request	max 0.5mA at 253 V-DC > 5M ohms on request
length tolerance	±1.5% (min. ±1mm) others on request	±2.5% (min. ±1mm) others on request	±1.5% (min. ±1mm) others on request	±1.5% (min. ±1mm) others on request	±1.5% (min. ±1mm) others on request
Wattage tolerance (cold)	±10% smaller on request	±10% smaller on request	±10% smaller on request	±10% smaller on request	±10% smaller on request
resistance tolerance	±10% smaller on request	±10% smaller on request	±10% smaller on request	±10% smaller on request	±10% smaller on request
diameter tolerance	metric = -0.02 to -0.06mm/ imperial = ±.0008"; total min. 0.02mm on request	metric = -0.02 to -0.06 total min 0.02 on request	metric = ±0.1	metric = ±0.1 smaller on request	metric = ±0.1 for diam 8mm to 18mm; ±0.15 for diam 19mm to 32mm; ±0.20 for diam 40mm
connection voltage	max 575V	max 250V	max 24V low safety voltage	max 440V depending on diameter	max 440V depending on diameter
maximum recommended sheath surface load	160 Watts per inch squared	100 Watts per inch squared	97 Watts per inch squared	80 Watts per inch squared (centerless ground)	32 Watts per inch squared
length of unheated zone	lead end: 4-10mm disc end: 4-9mm; others on request	lead end: 13mm; disc end: 6mm; smaller on request	lead end: min. 12mm; disc end: min. 3mm; others on request	lead end: 4-10mm; disc end: 4-9mm	lead end: min. 12mm; disc end: min. 3mm; others on request
imperial diameters available	1/8", 1/4", 5/16", 3/8", 1/2", 5/8", 11/16", 3/4", 7/8", 1"		5.0 or 6.5 others on request	1/4", 3/8", 1/2", 5/8", 3/4"	
metric diameters available	3.1, 6, 6.35, 6.5, 7, 7.9, 8.9, 9.5, 10, 11, 12, 12.5, 12.7, 13, 14, 15, 15.8, 16, 17.5, 18, 19, 20, 22, 25.4	4mm		6.5, 8, 9.5, 10, 12.5, 12.7, 15.8, 16, 19, 20 others on request	8, 9.5, 10, 11, 11.3, 12, 12.5, 12.7, 14, 15, 15.8, 16, 16.5, 17, 17.5, 18, 19, 19.5, 20, 21, 23, 24, 25, 31.5, 32, 40 others on request
maximum length available	105"	13.7	on request	118"	on request

hotset — in Germany, USA and 28 other countries all over the world:



- Argentina
- Australia
- Austria
- Belgium
- Brazil
- Czech Republic
- Denmark
- Finland
- France
- Great Britain
- Greece
- Hongkong
- India
- Israel
- Italy
- Japan
- Korea
- Netherlands
- New Zealand
- Philippines
- Portugal
- Singapore
- South Africa
- Spain
- Sweden
- Switzerland
- Taiwan
- Turkey

hotset® Corporation

