

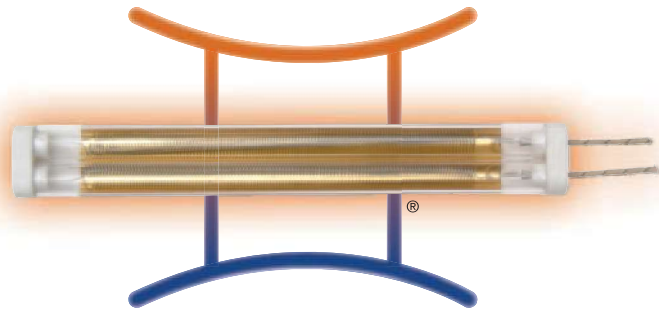

***Gemini® Infrared Heater  
Technology Emulates the  
Efficiency of Solar Energy  
in a Convenient Package for  
Hundreds of Industrial and  
Commercial Applications***



***Gemini™ Medium Wave Heaters  
Twin Bore Quartz Tube Technology***

**Design Features**

- \* *Industry standard twin bore quartz tube formats with 95% heat transmittance*
- \* *24-karat Gold Back Coating for targeted infrared applications*
- \* *White Ceramic Reflective Back Coating for extreme temperature requirements*
- \* *High power densities: 42/51/63.5 w/in (16/20/25 w/cm)*
- \* *Fast heat-up rates — Less than one minute to reach steady state conditions*
- \* *Very long operating life — Over 10,000 hours of highly efficient and economical continuous operation*
- \* *Three industry standard sizes in lengths up to 118 in. (3000mm)*



***Complete Infrared Heat Technology for Every Industrial  
and Commercial Application Under the Sun***

***Gemini Series – Managing the Power of the Sun in a More Convenient Package***

### Medium Wave Infrared E-Mitters

Tempco has developed specialized coatings to control the directional nature of the infrared energy emitted from the Gemini twin bore heaters. High levels of energy reflection are achieved by selectively bonding an integral high temperature coating to the half-hemisphere of the quartz tube surfaces facing away from the targeted sur-

face. The choice of a gold or white ceramic coating depends on the maximum operating temperature required in the heating system. Also available is a clear 360° E-Mitter for use in applications that will employ external reflective or focusing surfaces around the heater.

#### Gemini® Twin Tube Quartz Heaters with Gold Back Coating

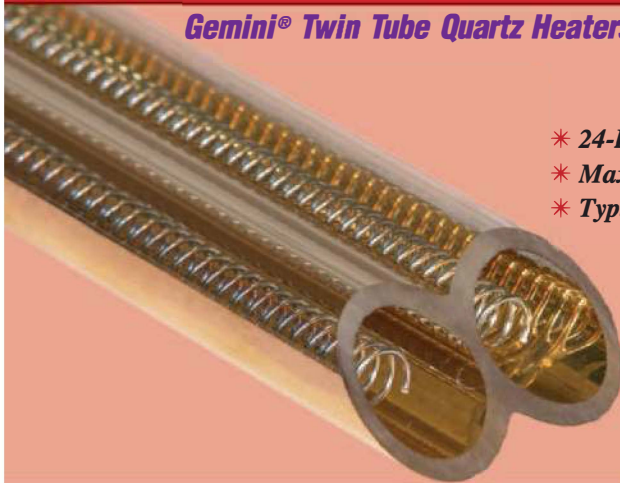

95% Heat Reflection toward working surface

- \* 24-Karat Gold Back Coating
- \* Maximum Coil Temp 1472°F (800°C)
- \* Typical Applications:
  - Glass Processing Industry
  - Paper and Textile Industries
  - Plastics Industry

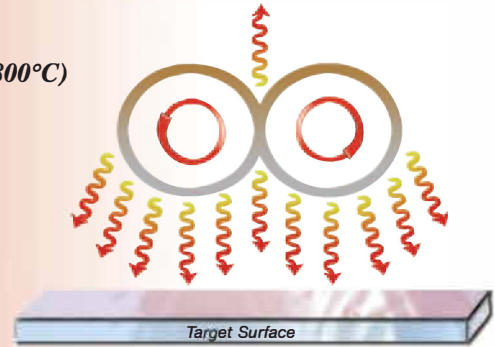

#### Gemini® Twin Tube Quartz Heaters with White Ceramic Back Coating



75% Heat Reflection toward working surface

- \* White Proprietary Formula Reflective Back Coating
- \* Maximum Coil Temp. 2012°F (1100°C)
- \* Typical Applications:
  - Stress Relieving of Metal Components
  - Drying Foils
  - Paper and Textile Industries

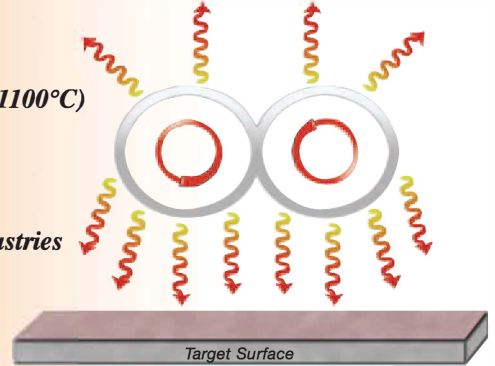

#### Gemini® Twin Tube Quartz Heaters Without Coating (for external reflector)



360° Heat Radiation

- \* No back coating
- \* Maximum Coil Temp. 2012°F (1100°C)
- \* Typical Applications:
  - PVC Panel Coating Cure
  - Curing Coating on Rubber Seals
  - Powder Coating Industry
  - Wood Processing Industry
  - Culinary Arts Industry

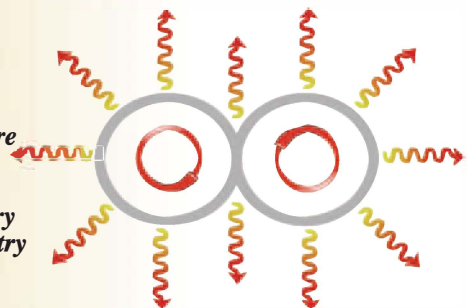

## Gemini Series

### Medium Wave Infrared E-Mitters

#### SPECTRAL EMISSIVITY OF PET FILM

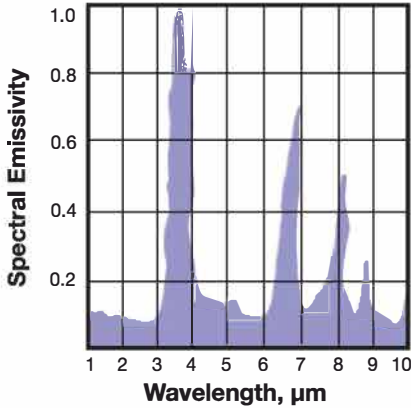

**WAVELENGTH CONTROL** – The very low heat transmission losses through the clear quartz material of the twin bore heaters allow Tempco’s engineers to carefully design the peak emitted wavelength of these heaters to match the peak absorption wavelength for a given material or application. By modifying the temperature of the E-mitter, its peak emitted wavelength will change according to Wien’s displacement law (see page 7-101). All E-mitters will emit a range of wavelengths above and below their peak value. (See spectrum graph on page 7-97.) The design of an efficient infrared heating system must consider both the spectral nature and directional properties of thermal radiation.

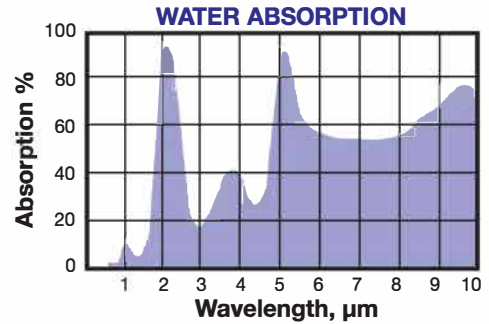

**SPECTRAL NATURE:** To address this issue, heaters should be designed to emit wavelengths that closely match the absorption band of the processed material in a given application. By carefully considering the broad side-bands of the emitted radiation and absorption, it is possible to design systems that will enhance the heat transfer rates at different stages of the heating process.

#### Infrared Energy Spectrum Emission

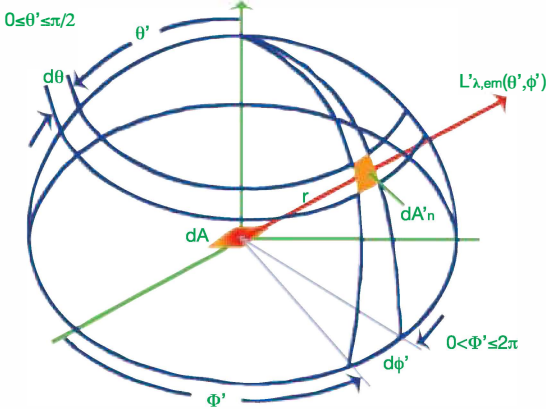

Vaporization of water is best achieved in the infrared spectrum at wavelengths in the range of 3.1 and 6.1  $\mu\text{m}$  (microns). After the water is removed, the infrared heating rate should match the absorption spectrum of the base material to avoid damaging it thermally. Similar approaches are used in many industries, such as automotive, glass and plastic processing, textiles, electronics and many others.

**DIRECTIONAL NATURE:** The directional nature of the heat distribution is dealt with by consideration of how to direct heat toward an application. The efficiency of the heating system depends strongly on the percentage of the total infrared energy generated at the resistance coil that reaches the target material. Consideration must be given to the fact that this infrared energy propagates from the E-mitter in all possible directions with a non-uniform wavelength distribution.

### Design Specifications

Performance Ratings			
Reflective Backing	Gold	White Ceramic	Clear* (no backing)
Maximum Coil Temperature	1472°F (800°C)	2012°F (1100°C)	2012°F (1100°C)
Peak Emitted Wavelength Range (microns)	2.7-6.5	2.1-6.5	2.1-6.5
Radiation Pattern	180°	180°	360°
Nominal Reflected Heat Efficiency	95%	75%	0%

\*Clear tubes are designed for use with external reflector.

Electrical Ratings			
Twin Bore Tube Size	18 × 8 mm	23 × 11 mm	33 × 15 mm
Maximum Power Density (per unit length)	42 w/in (16.5 w/cm)	51 w/in (20 w/cm)	63.5 w/in (25 w/cm)
Maximum Voltage	480V	480V	600V
Maximum Amperage per circuit	9.5A	13.5A	20A

Standard wattage tolerance is +5%, -10%; closer tolerances available upon request

## Medium Wave Infrared E-Mitters

Wire Leads for Standard Configuration are Stranded Lead Wire, Rated 842°F (450°C), 600V.

- OAL: Overall Length
- CS1: Lead End Cold Section
- HL: Heated Length
- CS2: Blind End Cold Section

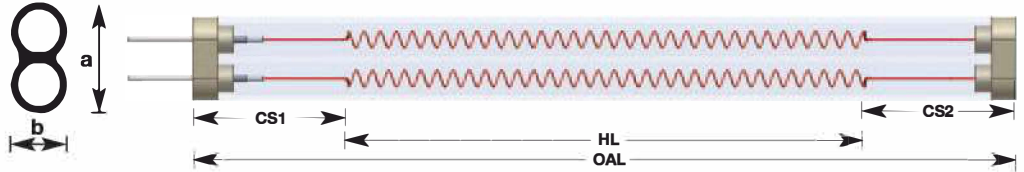

### Dimensional Specifications

Twin Tube Size Dimensions (a x b)	18 x 8 mm (.71 x .31 in)	23 x 11 mm (.91 x .43 in)	33 x 15 mm (1.30 x .59 in)
Maximum Length (OAL)	2000 mm (78.75 in)	2000 mm (78.75 in)	3000 mm (118 in)
Minimum Lead End Cold Length (Standard CS1) (both ends of double end units)	50 mm (1.96 in)	50 mm (1.96 in)	50 mm (1.96 in)
Minimum Blind End Cold Length (Standard CS2) (single ended units only)	50 mm (1.96 in)	50 mm (1.96 in)	50 mm (1.96 in)
Overall Length (OAL) Tolerance	± 2.5 mm (0.10 in)		
Heated Length (HL) Tolerance	± 6.5 mm (0.26 in)		

Consult factory for closer tolerances.



### Exceptional Clear Quartz Twin Bore Material with Proven Application Results

- ➔ **Automotive:** Airbag assembly, headliner formation, roof rack bonding, mirror manufacturing, flux powder drying, adhesive activation on protective strips, powder coating, spot repair, friction material bonding, plastic bumper drying, forming & painting
- ➔ **Plastics:** PET bottle blow molding, pellet/granulate drying, polypropylene fiber fusing, plastic component extruding/bending, ink drying, and laminating
- ➔ **Glass:** Preheating, coating/paint curing, light bulb production
- ➔ **Food Industry:** Chocolate processing, cake heating/baking, food warming
- ➔ **Paper, Electronics**      ➔ **Metals**      ➔ **Semi-conductor Processing**  
➔ **Textiles,**                      ➔ **Furniture**      ➔ **And much more**

## Gemini Series

### Standard Design (Non-Stock) Gemini Medium Wave Infrared E-Mitters

Leads for Standard Configuration are Stranded Lead Wire, Rated 842°F (450°C), 600V.

OAL: Overall Length  
CS1: Lead End Cold Section  
HL: Heated Length  
CS2: Blind End Cold Section

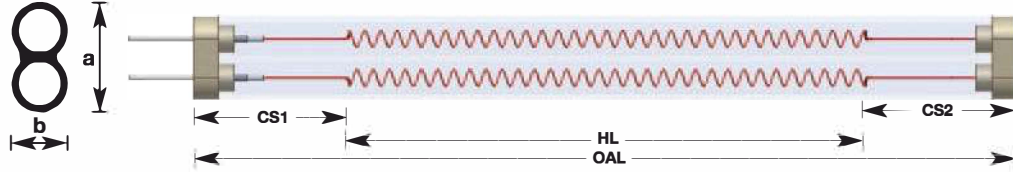

Twin Bore Quartz Format Dimensions				Overall Length		Heated Length		Power Watts	Part Numbers @ 230 Volts Coatings			Linear Power Watts per inch	Configuration Style	Lead Exit Angle
a		b							Gold	White	None			
in	mm	in	mm	in	mm	in	mm							
0.71	18	0.31	8	15.7	400	11.8	300	500	GEM00001	GEM10001	GEM20001	42.4	A	0°
0.91	23	0.43	11	23.6	600	19.7	500	1000	GEM00002	GEM10002	GEM20002	50.8	A	0°
1.30	33	0.59	15	35.4	900	31.5	800	2000	GEM00003	GEM10003	GEM20003	63.5	A	0°
1.30	33	0.59	15	43.3	1100	39.4	1000	2500	GEM00004	GEM10004	GEM20004	63.5	A	0°
0.91	23	0.43	11	51.2	1300	47.2	1200	2500	GEM00005	GEM10005	GEM20005	53.0	A	0°
1.30	33	0.59	15	55.9	1420	51.2	1300	3250	GEM00006	GEM10006	GEM20006	63.5	A	0°
1.30	33	0.59	15	63.0	1600	59.1	1500	3750	GEM00007	GEM10007	GEM20007	63.5	A	0°
1.30	33	0.59	15	66.9	1700	63.0	1600	4000	GEM00008	GEM10008	GEM20008	63.5	A	0°
1.30	33	0.59	15	70.9	1800	66.9	1700	4100	GEM00009	GEM10009	GEM20009	61.3	A	0°
1.30	33	0.59	15	75.6	1920	70.9	1800	4500	GEM00010	GEM10010	GEM20010	63.5	A	0°
1.30	33	0.59	15	83.5	2120	78.7	2000	5000	GEM00011	GEM10011	GEM20011	63.5	B	0°
1.30	33	0.59	15	102.4	2600	98.4	2500	6250	GEM00012	GEM10012	GEM20012	63.5	B	0°
0.71	18	0.31	8	15.7	400	11.8	300	500	GEM00013	GEM10013	GEM20013	42.4	A	90°
0.91	23	0.43	11	23.6	600	19.7	500	1000	GEM00014	GEM10014	GEM20014	50.8	A	90°
1.30	33	0.59	15	35.4	900	31.5	800	2000	GEM00015	GEM10015	GEM20015	63.5	A	90°
1.30	33	0.59	15	43.3	1100	39.4	1000	2500	GEM00016	GEM10016	GEM20016	63.5	A	90°
0.91	23	0.43	11	51.2	1300	47.2	1200	2500	GEM00017	GEM10017	GEM20017	53.0	A	90°
1.30	33	0.59	15	55.9	1420	51.2	1300	3250	GEM00018	GEM10018	GEM20018	63.5	A	90°
1.30	33	0.59	15	63.0	1600	59.1	1500	3750	GEM00019	GEM10019	GEM20019	63.5	A	90°
1.30	33	0.59	15	66.9	1700	63.0	1600	4000	GEM00020	GEM10020	GEM20020	63.5	A	90°
1.30	33	0.59	15	70.9	1800	66.9	1700	4100	GEM00021	GEM10021	GEM20021	61.3	A	90°
1.30	33	0.59	15	75.6	1920	70.9	1800	4500	GEM00022	GEM10022	GEM20022	63.5	A	90°
1.30	33	0.59	15	83.5	2120	78.7	2000	5000	GEM00023	GEM10023	GEM20023	63.5	B	90°
1.30	33	0.59	15	102.4	2600	98.4	2500	6250	GEM00024	GEM10024	GEM20024	63.5	B	90°

### Optional Winding Patterns

Using alternate stretching configurations to achieve distributed wattage, Tempco can easily customize Gemini series heaters to fit your application. Below are various configurations with "A" Standard for Single Ended and "B" Standard for Double Ended.

#### Single Ended Terminations

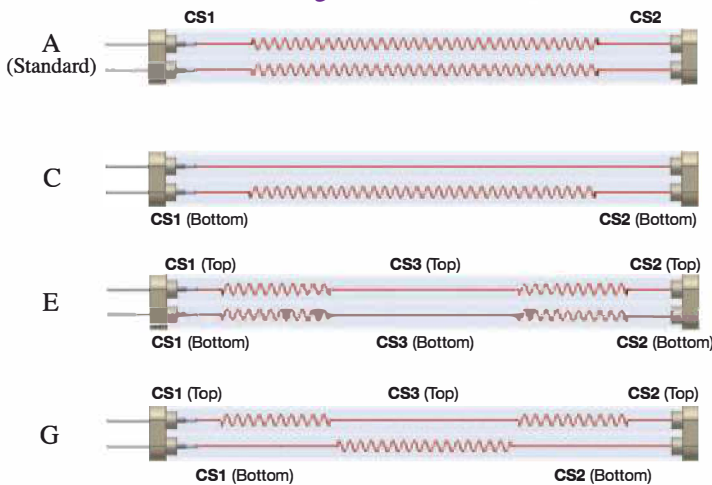

#### Double Ended Terminations

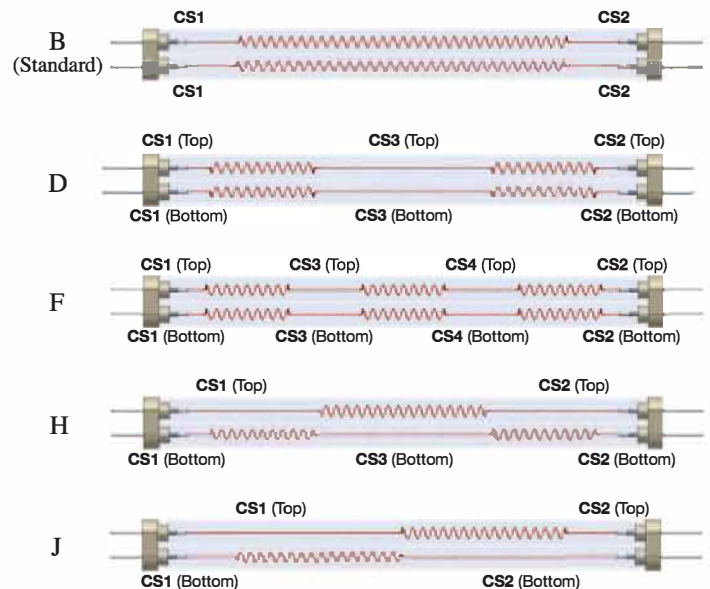

**Gemini Medium Wave Infrared E-Mitters**

**Lead configurations and lengths** – 842°F (450°C), 600V insulated lead wire, 3/8" stripped ends standard, oriented straight out ends or at 90° to heater axis. Optional styles of high temperature insulated lead wire and un-insulated ring or spade terminals are available to suit your application. Select size and style from charts

on page 7-23. Bare stranded heater leads up to 9" long may be ordered with optional ceramic bead insulators. Longer lengths are available as lead wire options only. When ordering, specify lead orientation, style, length, and terminals.

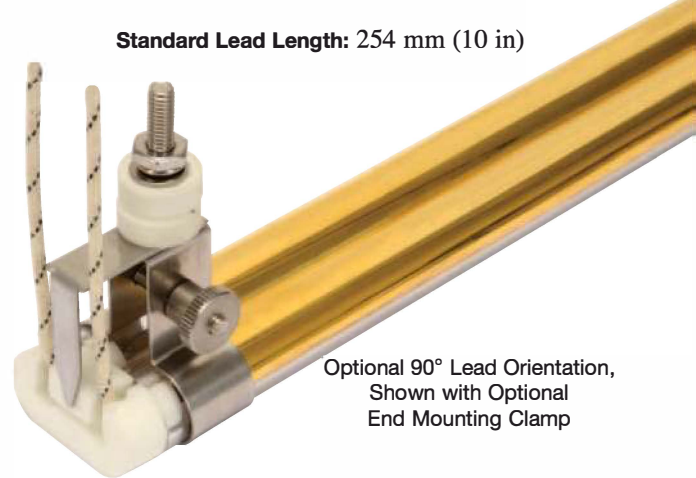
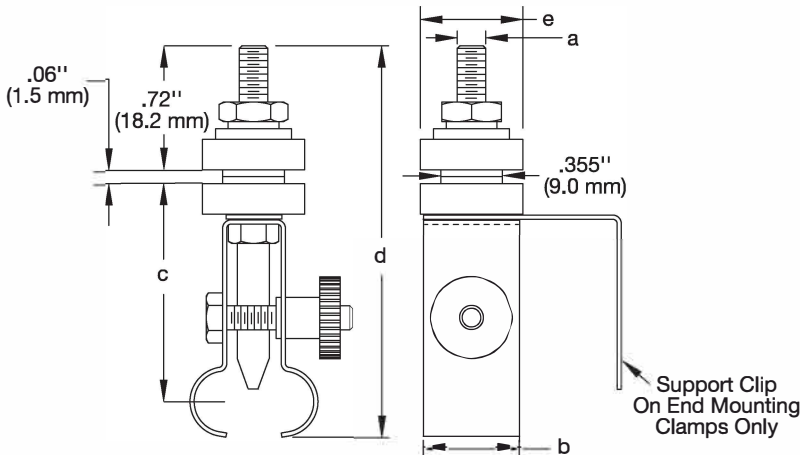

**Gemini Stainless Steel Clamp Specifications and Dimensions**

Clamp Assembly Part Number	CRK00085	CRK00086	CRK00087	CRK00088	CRK00089	CRK00090
<b>Fits Twin Tube Size</b>	<b>18 × 8 mm</b>		<b>23 × 11 mm</b>		<b>33 × 15 mm</b>	
<b>Clamp Location on Tube</b>	Center	End	Center	End	Center	End
<b>Clamps Required</b>	OAL > 39.4" (1000 mm)	2 per heater	OAL > 59.1" (1500 mm)	2 per heater	OAL > 78.7" (2000 mm)	2 per heater
<b>Mounting Stud Threads (a)</b>	10-32		10-32		10-32	
<b>Clamp Width (b)</b>	0.40" (10.2 mm)		0.40" (10.2 mm)		0.60" (15.2 mm)	
<b>Heater Mounting Height (c)</b>	1.20" (30.5 mm)		1.20" (30.5 mm)		1.41" (35.8 mm)	
<b>Overall Clamp Height (d)</b>	2.44" (62 mm)		2.48" (63.1 mm)		2.77" (70.3 mm)	
<b>Ceramic Insulator Diameter (e)</b>	0.59" (15 mm)		0.59" (15 mm)		0.59" (15 mm)	
<b>Panel Mounting Hole Diameter</b>	0.375" (9.5 mm)		0.375" (9.5 mm)		0.375" (9.5 mm)	

Recommended mounting panel thickness range is 18-14 ga.

**Ordering Information**

**Stock Heaters**

Order by Tempco Part Number for heaters listed on page 7-66.

**Custom Engineered/Manufactured Heaters**

Because TEMPCO understands that an electric heater can be very application specific, for sizes not listed TEMPCO will design and manufacture a Gemini Infrared Heater or modular housing to meet your requirements. **Standard lead time is 3 weeks.**

**Please Specify the following:**

- Reflective Coating — Gold, White Ceramic or None
- Twin Bore Tube Size (18 × 8 mm, 23 × 11 mm, or 33 × 15 mm)
- Wattage or Watts/In
- Single or Double End
- Overall Length (OAL)
- Heated Length (HL)
- Lead Orientation (0° or 90°)
- Voltage
- Quantity
- Lead Wire Terminals (page 7-23)
- Lead Wire Style/Length (Page 7-23)
- Winding Pattern (page 7-66, A-J or as required)
- Ceramic Bead Option (9" max. length)
- CRA Linear Housing Option (See page 7-68)
- Cold End Lengths (CE1 & CE2) See Winding Pattern page 7-66

**WARNING:** Cancer and Reproductive Harm - [www.P65Warnings.ca.gov](http://www.P65Warnings.ca.gov).

### Gemini Series

### Gemini Medium Wave Infrared E-Mitter Assemblies using a CRA Linear Housing

#### CRA Linear Modular Housing Assemblies

These compact assemblies have one 33 × 15 mm twin bore Gemini quartz heater mounted in front of an aluminized steel reflector at a power density of 63.5 w/linear inch.

#### Design Features

- \* Rapid heat-up/cool-down and low residual heat retention
- \* Compact lightweight extruded anodized housing
- \* High efficiency aluminized steel reflector for harsh environments and high temperature applications
- \* Adaptable to all Gemini twin bore sizes

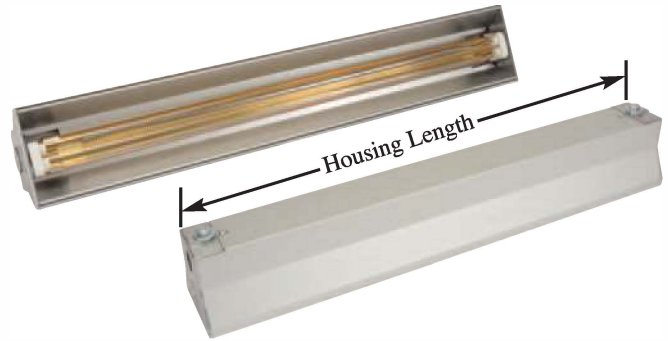

### Standard (Non-Stock) and Stock Sizes and Electrical Ratings – 230V

Stock Items Are Shown In **RED**

Watts	Housing Length		Heated Length (HL)		Housing Assembly Part Number			Replacement Heater Part Number			Winding Pattern See Page 7-66
	in	mm	in	mm	Heater Back Coating			Heater Back Coating			
					Gold	White	None	Gold	White	None	
2000	36.19	919	31.5	800	CRA80001	CRA80015	<b>CRA80024</b>	GEM00015	GEM10015	<b>GEM20015</b>	A
2500	44.06	1119	39.4	1000	CRA80002	CRA80016	<b>CRA80025</b>	GEM00016	GEM10016	<b>GEM20016</b>	A
3250	56.63	1438	51.2	1300	CRA80003	CRA80017	<b>CRA80026</b>	GEM00018	GEM10018	<b>GEM20018</b>	A
3750	63.75	1619	59.1	1500	CRA80004	CRA80018	<b>CRA80027</b>	GEM00019	GEM10019	<b>GEM20019</b>	A
4000	67.69	1719	63.0	1600	CRA80005	CRA80019	<b>CRA80028</b>	GEM00020	GEM10020	<b>GEM20020</b>	A
4100	71.65	1820	66.9	1700	CRA80006	CRA80020	<b>CRA80029</b>	GEM00021	GEM10021	<b>GEM20021</b>	A
4500	76.38	1940	70.9	1800	CRA80007	CRA80021	<b>CRA80030</b>	GEM00022	GEM10022	<b>GEM20022</b>	A
5000	84.25	2140	78.7	2000	CRA80008	CRA80022	<b>CRA80031</b>	GEM00023	GEM10023	<b>GEM20023</b>	B
6250	103.13	2620	98.4	2500	CRA80009	CRA80023	<b>CRA80032</b>	GEM00024	GEM10024	<b>GEM20024</b>	B



**Warning:** Gemini Heaters are designed to be used in a horizontal position only.

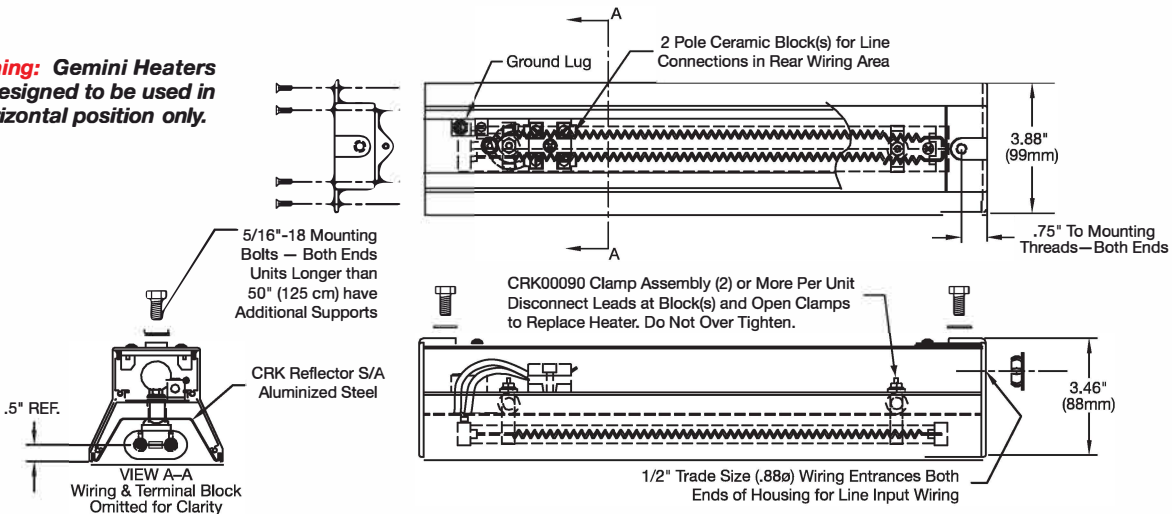

### Ordering Information

Select a Part Number from the Standard Sizes and Electrical Ratings table that meets your requirement.

Custom housings are available for any twin tube size (18 × 8 mm, 23 × 11 mm, and 33 × 15 mm; see page 7-67) Gemini Series Heater. Specify watts, volts and heated length (or w/in) required and TEMPCO will design a unit to suit your application. Clear, gold, or white ceramic coated heaters and doubled end wiring, and chrome steel reflector options are available.

**Wiring Diagrams for Gemini E-Mitter in a CRA Linear Housing**

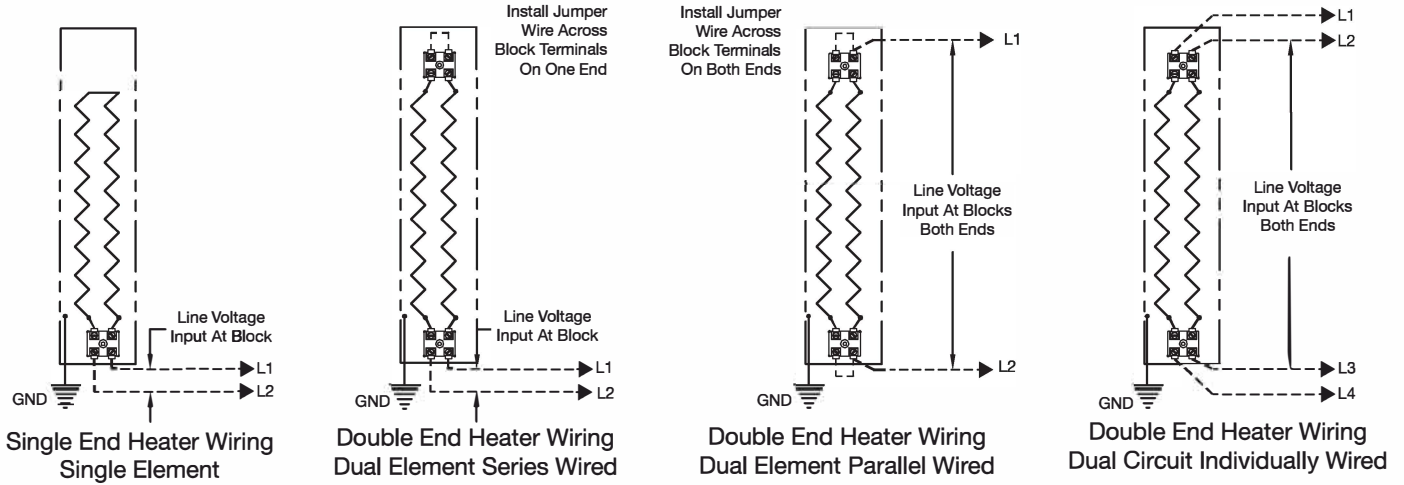

**Warning:** Hazard of Electrical Shock. Installation must be grounded to earth. Disconnect power before installing or servicing heater.

**Minimum Spacing Between Gemini Medium Wave Heaters**

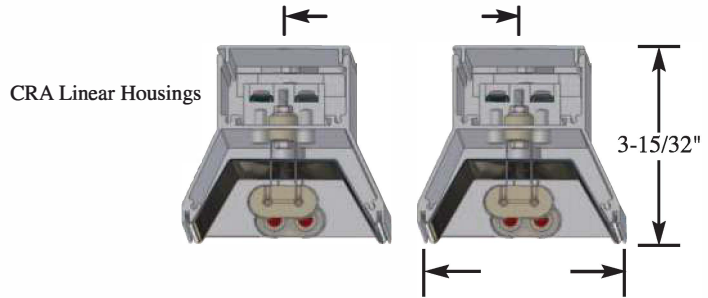
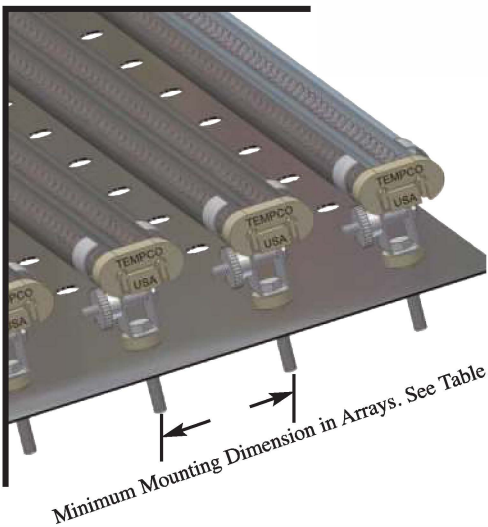

**Minimum Spacing between Heaters in Array Assemblies ("D" Dim.) and CRA Linear Housings**

Twin Bore Tube Size	18 x 8 mm	23 x 11 mm	33 x 15 mm
Minimum Center to Center Spacing of Heaters Mounted in ARG Arrays ("D Dim.")	1.43"	1.63"	2.00"
Minimum Center to Center Spacing of Heaters Mounted in CRA Linear Housings	4.00"	4.00"	4.00"

**Type ARG Gemini Medium Wave Infrared E-Mitter Panel Arrays**

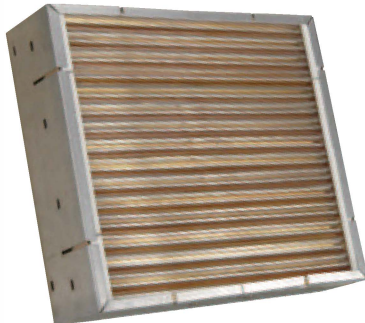

Custom panel arrays are available. Tempco will design and build to your specifications. Consult us with your requirements.

