



Main features

- Operator interface with color touch screen display, 3.5 "
- Up to 8 PID control loops
- Cascade, ratio and valve PID controls
- Profile programmer with ramps and retention; synchronous and asynchronous
- Up to 200 Programs with 50 segments
- 3 password protected user levels
- Energy meter (kWh)
- Configurable logic operations
- Configurable math functions
- Data Log with Real Time Clock
- Batch Report management
- Open format files (CSV) or encrypted for DataLog and production batches
- Setting up custom pages
- Management of active and historic alarms
- Active and historical alarm management
- USB for data export and parameter cloning
- Control parameter advanced tuning
- Configurable analogue and digital I/O signals
- HMI/SCADA/PLC data exchange via Ethernet Modbus TCP
- Message language selection

PROFILE

The 2850T multifunction controller is designed to control the temperature in production processes (heat treatment, kiln and autoclave management, etc.) used in different industrial sectors such as automotive, food, metalworks, etc.

The controllers consist of three elements: the operator interface with touch screen display and keys, the I/O module group for connection to plants and machinery and the connection cable between the interface and the module group.

The **color touch screen display** 3,5" allows the operator to easily and quickly interact with the controller, managing actions and parameters.

Access to the main controller functions and navigation between pages is made easier thanks to its 6 **function keys**, some of which are customisable.

Customized pages may be configured directly on the display, even without a PC or external software. This option allows you create optimised graphic interfaces to control the machinery used. A graphic symbol library is provided for this purpose (buttons, bargraph, data display, etc.) that can be set and linked to the controller variables. You may also import images, such as representations of the machinery

or of the system's operating diagram, to be used as a background, to make control even more intuitive for operators.

The controller can manage up to 8 PID loops, fully configurable. Each PID can be used as a control for a single loop, a valve or a ratio control, it can be connected to the profile programmer or be used as a cascade controller.

Tuning is performed through advanced algorithms that ensure stable and accurate temperature control, avoiding exceeding set limits or having unstable process control even in critical heat or fast motion processes.

The **setpoint profile programmer** allows you to set the programs to manage heat treatment cycles. The profile is the set of segments that describe the setpoint curve. You can create up to 200 programs, stored internally, each of which can contain up to 50 segments.

Each program lets you set up to four setpoint profiles. A descriptive message, 16 input events (IN), 16 outbound events (OUT), the setpoint value and the HBB alarm threshold can be set for each program.

You can launch up to four programs simultaneously, each of which can handle up to 4 synchronous profiles.

The profile programmer can be set in synchronous mode (all profiles are run with

a common time base) or asynchronous (each profile can be run with an independent time base). The asynchronous mode is obtained by running different programs simultaneously.

The available logical operators (AND, OR, Timer, Counter etc.) allow you to create custom **logic operating** sequences integrated with the PID, thus obtaining complete and flexible machine control.

The available **settable mathematical functions** (addition, multiplication, division, minimum or maximum value, algorithms, etc.) can be used associated with process values as analog channels and virtual channels, to manage advanced controls, such as ratio controls or custom mathematical formulas.

The **Data Logger function**, combined with the Real Time Clock (RTC clock with rechargeable buffer battery) stores process data, IN/OUT signals and the status of the alarms in an open file (.CSV format) or encrypted file. The minimum data sampling frequency is 1 second. Saved files can then be exported from the controller via USB or Ethernet network.

The **batch report** option lets you to associate this data with a specific batch produced, to be able to use them in production and quality reports.

A specific application for PC (**Report Utility**) is available for easy management of all data logger data and the production batch reports which allows you to copy and delete files via an Ethernet network between the controller and a PC, manually by the operator or automatically at configurable time. The data stored on the PC can then be displayed in graphical format or a spreadsheet (Excel type) or exported as CSV or PDF files.

For the quick and safe installation of the machinery or plant, use the **recipes** stored in the controller. The recipes, easily retrievable by the operator, can be of two types: **OEM manufacturer recipes**, which contain the machine setup parameters and **production recipes**, which contain single production settings (profile program, logical steps, math functions). The recipes can be easily transferred between different controllers via USB key or Ethernet network.

Controllers offer **complete diagnostics** (probe break down or incorrect connection, total or partial load break down, control loop faults), which helps the operator in

case of controlled machine or process faults.

All **controller alarms** are stored internally and can be viewed as Active alarms and Historical alarms. The relevant message is displayed for each historical alarm with the date and time of the various states (active alarm, ACK, and alarm cleared). The ACK parameter, settable for each alarm, ensures that the active alarm was acknowledged by the operator.

An **internal energy counter**, with configurable offset alarm, provides energy consumption and cost totals.

For **accurate time stamps**, the controller supports the Simple Network Time Protocol (SNTP) service, which continuously updates the controller's date and time from the SNTP server connected via Ethernet network.

The **weekly clock** function lets you automatically start or stop a programmer or a process, without the need of operator intervention.

The clock is based on a settable weekly calendar (day of week and time).

The display **language selection** lets the operator interact with the device in the preferred language, facilitating work.

Secure access to all controller parameters is guaranteed by **3 preconfigured password levels** (Operator, Maintenance technician and OEM manufacturer). In this way, each user can only access the assigned functions and parameters.

You can connect the controller to the factory HMI/SCADA network by using standard **Modbus TCP (Ethernet) connectivity**.

Complete controller configuration is facilitated by use of the PC programming tool GF_express, which proposes intuitive Wizard pages, permitting easy construction of customized graphic pages and advanced logic.

DISPLAY AND KEYS

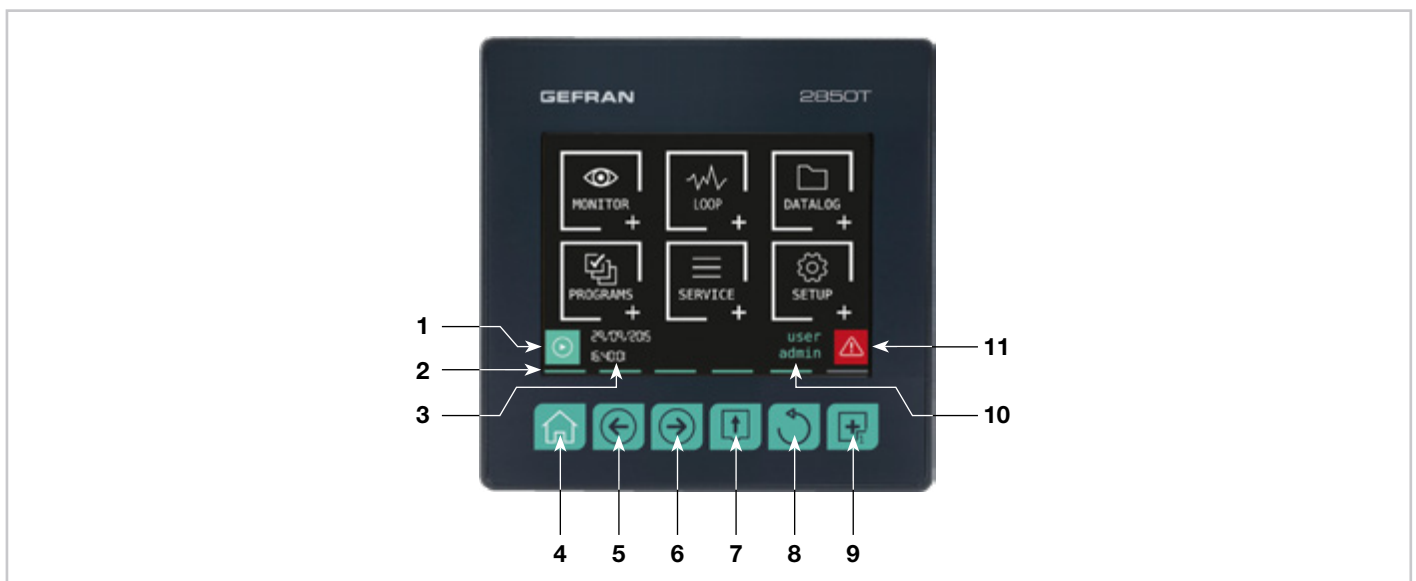
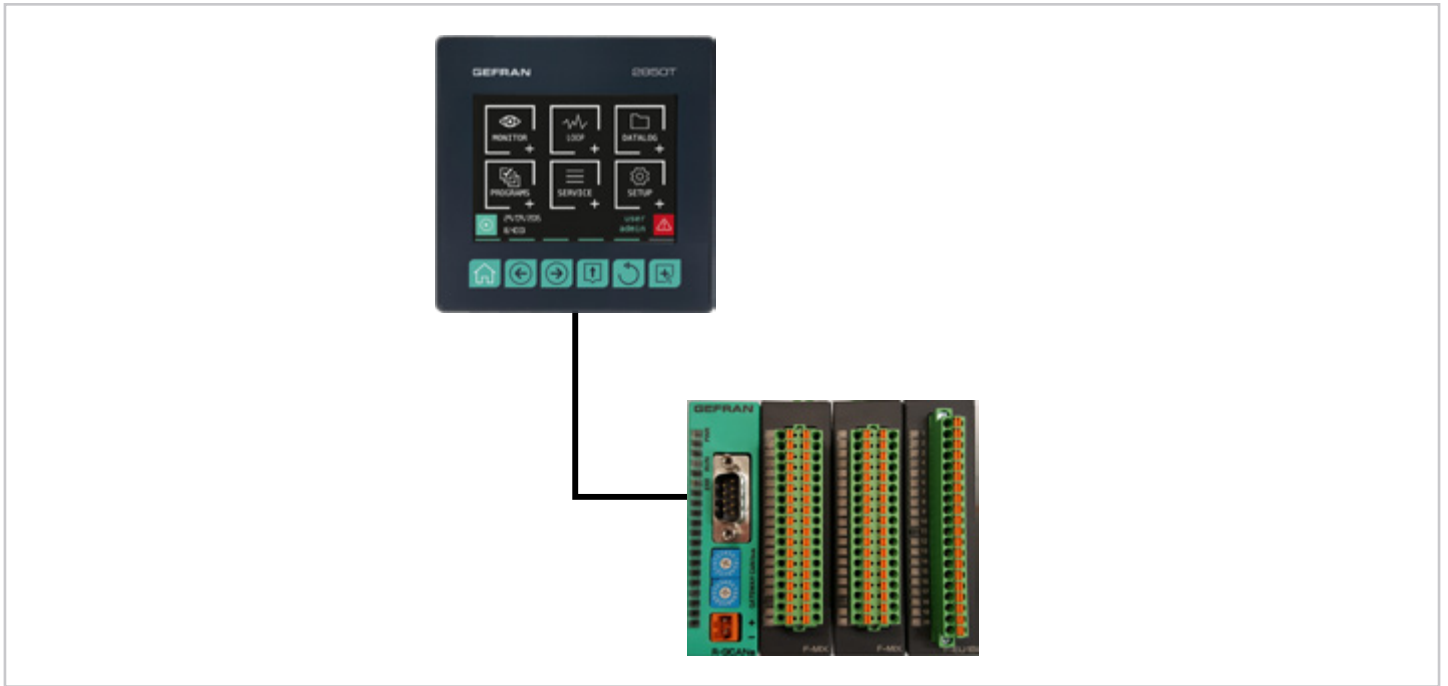

Figure 1 - 2850T display and key description

1. Shortcut icon (the landing page depends on the option chosen):
 - Controller with PROGRAMMER option: go to the Program Monitor page that displays main program information and lets you manage its execution. If the program that is opened is intended for recording only, the simplified interface will open, as in the case of the RECORDER.
 - Regulator with RECORDER option: go to page for starting and stopping recording.
2. Lighted pressed key conformation.
3. Date and time indication.
4. Home page key: return to the main menu.
5. Left Page key: changes the page in the submenus with multiple pages.
6. Right Page key: changes page in the submenus with multiple pages.
7. Group Page key: go to the higher menu level.
8. Back key: return to the previous page.
9. Custom Page 1 button: go to first custom page
10. Authenticated user indication. The login page opens by touching the indication.
11. Alarm Icon: blinks to indicate an alarm; tapping the icon opens the page that lists current alarms.

HARDWARE ARCHITECTURE



DIMENSIONS AND DRILLING TEMPLATES

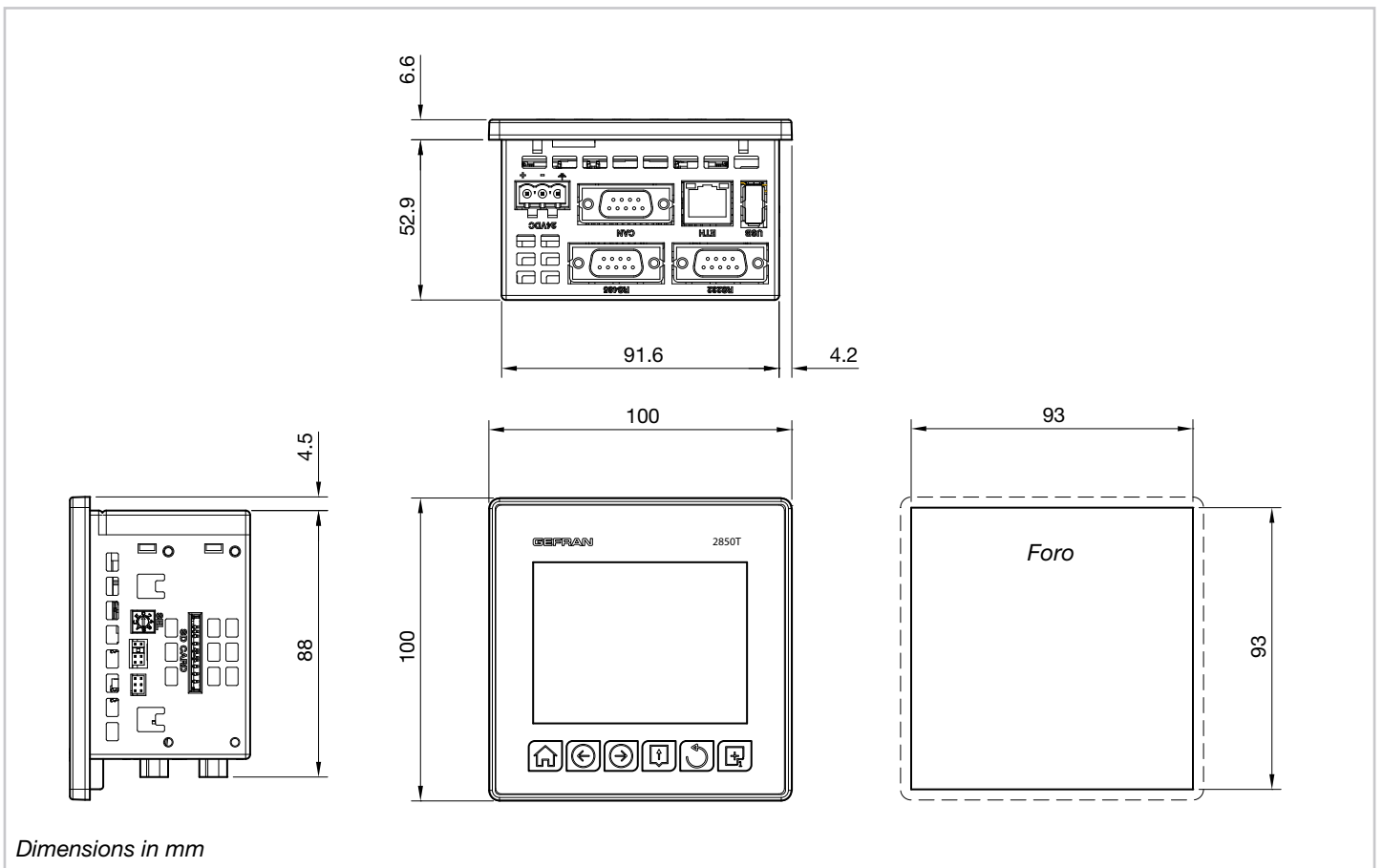

I/O MODULE DIMENSIONS

I/O 2 SLOT

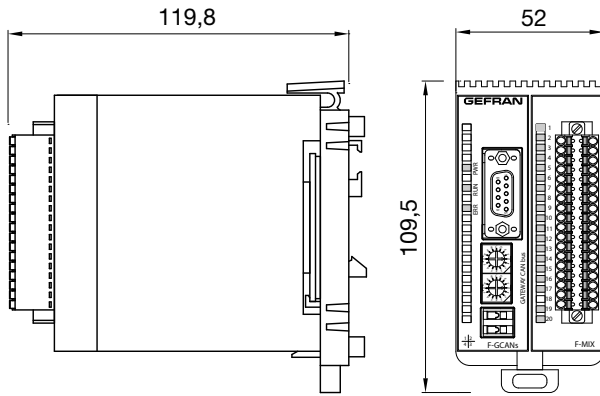

I/O 4 SLOT

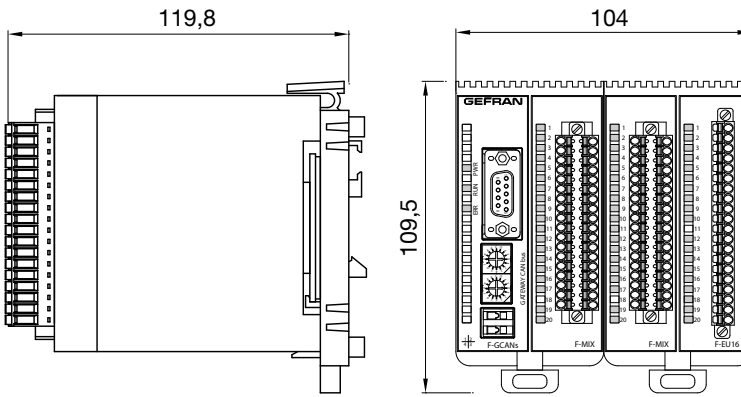

I/O 8 SLOT

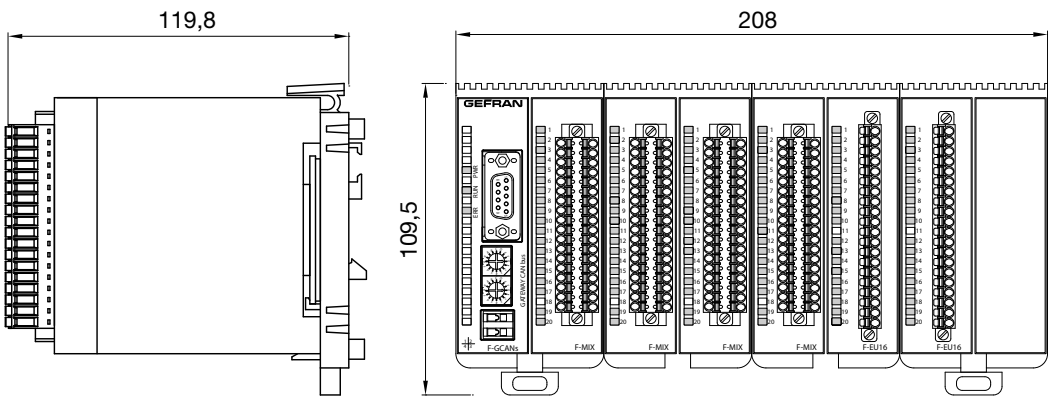

Dimensions in mm

I/O MODULE COMPOSITIONS

Composition	Mod. ¹	Analog		Digital		Tot. I/O	2850T code	
		IN	OUT	IN	OUT			
Standard		2	4	2	8	8	22	2850T-xx-04-xx-xx-xx-xx-xx-00-x-x
		4	8	4	16	16	44	2850T-xx-08-xx-xx-xx-xx-xx-00-x-x
with additional digital expansions		4	4	2	16	16	38	2850T-xx-04-xx-xx-xx-xx-xx-08-x-x
		4	8	4	24	24	60	2850T-xx-08-xx-xx-xx-xx-xx-08-x-x
		4	4	2	24	24	54	2850T-xx-04-xx-xx-xx-xx-xx-16-x-x
		8	8	4	32	32	76	2850T-xx-08-xx-xx-xx-xx-xx-16-x-x

Notes

- 1) Container dimensions in modules
n/a = composition not available

TECHNICAL SPECIFICATIONS
2850T controller

OPERATOR INTERFACE		
DISPLAY	Type	TFT Touch Screen with 4-wire resistive type technology
	View area	Diagonal: 3,5" Dimensions (L x H): 70 x 52,5 mm (2.57" x 2.07")
	Lighting	Back lit with LED, duration 50.000 hours @ 25 °C (77 °F)
	Resolution (pixel)	320 x 240 (QVGA)
	Colors	262,000
	Max brightness	400 cd/m ²
	Contrast	400:1
View angle	Horizontal: 60° Vertical: +45° ... -60°	
KEYBOARD		Number of keys: 6 Type: mechanical
CONTROL FUNCTIONS		
LOOP (Regulation)	Type	Single loop; Cascade (2 consecutive PID: PID1-PID2, PID3-PID4 ...); Ratio; Valve
	PID	Number: 8 max Parameter groups: 10 max
	Regulation type	PID ON/OFF Single action heat or cool Double action heat or cool
	Control output	Type: continuous (0... 100%) or ON/OFF with PWM modulation. Cycle time: constant or optimised (Burst Firing)
	Valve control	Open/close for floating type motorized valve Open/close for motorized valve with feedback (potentiometer position control)
	Sampling time	25 ms
	Tuning	Automatic Self Tuning algorithms
	Alarms	Number: max 4 associated with each PID Type: maximum, minimum, symmetric, absolute/relative
SETPOINT PROGRAMMER	Programmer type	Synchronous and asynchronous setpoint programs Single-segment setpoint or ramp + maintenance profile Integrated function blocks
	Program profile	From 1 to 4 synchronous profiles
	Program	Max number of programs: 200 Maximum number of programs running at the same time: 4 Available commands: START, HOLD/PAUSE, RESET, END, SKIP Status outputs: RUN, READY, END, HOLD
	Segments	Setting: time segments (hh: mm / mm: ss / dd: hh) or gradient configuration Maximum number of segments per program: 50 Maximum number of ramps and holds per program: 100 (50 ramps - 50 holds) High/low limit threshold configurable for each segment PID group activation for each segment
	IN profile events	Max number of settable IN events: 16 Acknowledged events: digital IN-resource, digital OUT, system marker
	OUT profile events	Max number of settable OUT events: 16 ON/OFF while running the profile segment Events acknowledged: digital OUT resource, logic operation, programmer status
	Simplified configurability	Template Configuring and running the same program on several PIDs simultaneously
	HBB alarm	Alarm range configuration per single segment High/low range setpoint

GETLogic	Scope	Sequential execution of logical and mathematical instructions
	Running sequences	1 for each program (max 4) + 1 global always active
	Function blocks	Max number per program: 400
	Logic function blocks	AND, OR with default logic patterns Set/Reset, Reset/Set Rising edge, trailing edge
	Timer function blocks	Excitation delay timer (TON) De-energising delay timer (TOFF) Flip/flop timer
	Counter function blocks	Increasing counter Decreasing counter
	Basic mathematical function blocks	+ , - , × , : , average, minimum value, maximum value, square root, base 10 logarithm, natural base A logarithm, and raised to the power A, A raised to the power B
	Special mathematical function blocks	Max peak, minimum peak, hold of a value, average of 2 values, minimum/maximum limit of a value
	Special mathematical function blocks	Selection between two values Greater/Lesser/Equal/Greater-Equal/Lesser-Equal/Different
	Process function blocks	F0 (sterilisation coefficient)
	Resources for mathematics operators	Analog IN/OUT, SP controller, System Log/Real data
	Resources for logical operators	Digital In/Out, Alarm Status, System Merker
	DATA LOGGER	Scope
Recordable values		Max number of analog values: 25 Max number of digital events: 50
Sampling		Sampling interval: 1 s ... 1 h Sampling mode: single record with time information (date/time) and values/events/actions detected Closing the sequential log file: automatic every hour/day/week (configurable)
Data storage		File format: CSV Data file encryption: optional Log file name with close date/time indication Storage media: internal memory File export: manual via USB key or manual/automatic via Ethernet via <i>Gefran - DataLog Utility PC</i> application - <i>Report Utility</i>
Graphic display		Graph: stored log data trend Max number of viewable curves: 8 Data selection by association: 8 curves Single curve scaling Available functions: enable single curve, full scale selection, zoom +/-, scroll +/- and cursor
PRODUCTION REPORT (Batch report)	Scope	Synchronous recording when running the program profile
	Recordable values	Max number of analog values: 25 Max number of digital events: 50 Batch name/description (selectable) Running profile data (selectable)
	Sampling	Sampling interval: 1 s ... 1 h Sampling mode: single record with time information (date/time) and values/events/actions detected
	Data storage	File format: CSV Data file encryption: optional Log file name with close date/time indication and Job ID reference (optional) Storage media: internal memory File export: manual via USB key or manual/automatic via Ethernet via <i>Gefran - DataLog Utility PC</i> application - <i>Report Utility</i>
	Graphic display	Graph: stored log data trend Max number of viewable curves: 8 Data selection by page: 8 curves Single curve scaling Available functions: enable single curve, full scale selection, zoom +/-, scroll +/- and cursor

TREND GRAPH REAL TIME	Scope	Continuous recording of data configured without archiving
	Recordable values	Max number of analog and digital values: 24
	Graphic display	Max number of viewable curves by page: 24 Number of samples: 5,000 Single curve scaling Available functions: enable single curve, full scale selection, zoom +/-, scroll +/- and cursor
PROGRAM RECIPE	Data file	Programmer profile segment/event configuration Synchronised programmer logic operations Synchronised programmer mathematics functions DataLog/Batch data configuration
	References	Descriptive name and ID code (easy loading and activation)
	Data import and export	Via USB key
CONFIGURATION RECIPE	Types	System: number of clocks, home page, program modes ... PID: all single PID configuration parameters GETView: custom page configuration InOut: analog channel range, decimal point configuration, unit of measure configuration Messages: custom text list
	Data import and export	Via USB key
GETView	Scope	Configure custom graphic pages directly from the controller panel
	Number of customisable pages	10 max
	Components	Available types: <ul style="list-style-type: none"> • Led: digital variable with color/text/image change • Notes: default text display • Text: fixed text display • Edit text: text view and edit • Progress: display a value as a bar (vertical/horizontal) • Data display: display of a numeric value • Data edit: view and edit a numeric value • Button: change the status of a digital value with status display (color/text/image) and change mode selection (momentary/toggle) • System: page change function with default list selection Maximum number of components of the same type per page: <ul style="list-style-type: none"> • Text (Note, Text, Edit text) and numerical (Display date, Edit date): max 40 • Key: max 20 • LED: max 20 • Progress: max 16 • Image: max 10 • System: max one link of each type
	Available functions	Add a new component Edit component parameters Delete a component Move a component Multiple component selection for move or delete Align multiple components left Align multiple components top
	Image functions	Image conversion tool from the most popular graphic file formats Image file import and export via USB key
WEEKLY CLOCK	Scope	Event (ON/OFF) on a weekly or daily basis
	Function	Configure ON/OFF event status by single day of the week Event time settings in hh:mm Enable the weekly clock Enable weekly repetition
	Number	4 max
MULTILINGUAL	Scope	Change message language
	Function	UNICODE support Custom message translation File import and export via USB key
	Available languages	Italian (ITA), English (ENG), French (FR)

DIAGNOSTICS	Scope	Controller operating status
	PID loop	Short circuit or probe opening Interrupted or partially interrupted load (HB alarm)
	Communication	Communication status between panel and I/O modules Communication error alarm
	I/O modules	Signal status and single channel values
	System	Disk Full Alarm
ALARMS	Number	254 max
	Function	Alarm message customisation ACK/no ACK selection Real alarm display priority order level settings
VARIABLES	Available types	Merker (boolean) Retain Merker (boolean) Register (32 bit with sign) Retain Register (32 bit with sign) Real (32 bit) Retain Real (32 bit) String (text message) Function
	Number	max 256 per type
USERS	Levels	Number of default levels: 3 (operator, level 0; Maintenance, level 1; OEM manufacturer, level 2)
	Safety	Password Automatic timed logout at operator level
	Internal functions	Add new user
REMOTE CONNECTIVITY	Modbus TCP	Modbus TCP Slave HMI/SCADA/DCS Data exchange systems
	VNC	Remote page standard interface Remote machine maintenance
DATALOG UTILITY PC (remote application)	Connection	Ethernet Server NTP (option)
	Function	Remote DataLog and batch management Encrypted DataLog and batch file decryption Manual controller file copy or deletion Timer Configuration for automatic controller file copy or deletion Data trend graphic display (with graph zoom and scroll) Data display in spreadsheet mode Data export in .CSV or .PDF format
GF_eXpress (PC configuration)	Connection	Ethernet
	Function	PID controller configuration read and write Graphic display and setting of parameters useful for Programmer functions Logic and mathematics operation settings and display Creating custom graphic pages
NON-VOLATILE MEMORY	Type	FRAM
	Capacity	32 kB retentive variables
	Write	Max number: > 10 ¹² cycles Retention: > 10 years @ 55 °C (95 °F), > 55 years @ 35 °C (131 °F)

GENERAL DATA		
VOLTAGE	Operating voltage	24 VDC ±25%
	Current absorption	300 mA max
	Dissipated power	7.5 W max
	Protections	For polarity exchange For short circuit
	Connection	Removable 3-pin polarised connector Screw terminals, max 2,5 mm ² (0.0038 in ²) (13 AWG) cable section
BUFFER BATTERY	Type	MI2032, not replaceable
	Specifications	Rechargeable Li-AI, 3 V 65 mAh
	Duration	10 years. High temperatures can reduce battery life.
	Power reserve in the absence of current	> 20 months
	Ethernet (ETH)	Connector: RJ45 Speed: 10 / 100 Mbit/s Signals: Green LED = connection, yellow LED = data transfer Protocols: FTP (File Transfer Protocol), Modbus TCP/IP Master/Slave
	USB	Connector: type A Type: Host Port Version: 2.0 Full Speed Current: 100 mA max File system for USB key (Flash Drive): FAT32
ENVIRONMENTAL CONDITIONS	Indoor	Use
	Operating temperature	0 ... +55 °C (32.. 131 °F) (according to IEC 68-2-14)
	Storage temperature	-20 ... +70 °C (-4... 158 °F) (according to IEC 68-2-14)
	Relative humidity	Max 95% RH non condensing (according to IEC 68-2-3)
PROTECTION RATING		IP 65 on the front (according to IEC 68-2-3)
ASSEMBLY	Positioning	On panel, front pull-out
	Installation requirements	Installation category: III Pollution rating: 2 Insulation: double
DIMENSIONS	(L × H × D)	100 × 100 × 59,5 mm (3.94" × 3.94" × 2.34") max
WEIGHT		0.25 kg (0.55 lb)
EC REGULATIONS	EMC conformity (electromagnetic compatibility)	Compliance with the 2014/30/EU Directive EMC Emission: EN 61000-6-4 EMC Immunity: EN 61131-2, EN 61000-4-2, EN 61000-4-3, EN 61000-4-4, EN 61000-4-5, EN 61000-4-6, EN 61000-4-8, EN 61000-4-11
	LV conformity (Low Voltage)	Compliance with the 2014/35/EU Directive LVD safety: EN 61010-1
UL REGULATIONS		Compliance with UL508 standard

F-GCANs communications module

GENERAL DATA		
VOLTAGE	Operating voltage	24 VDC \pm 25%
	Current absorption	2 A max
	Dissipated power	2.5 W
	Connection	Polarised connector with spring terminals, cable 1 mm ² (0.0015 in ²) (17 AWG) max
CONNECTIONS	CAN	Connector: DB9 Protocol: CANopen 2.0B, level CAN DS301 v.3.0, v4.0
SIGNAL ELEMENTS	Error	Red LED
	Running	Green LED
	Voltage	Yellow LED
ENVIRONMENTAL CONDITIONS	Indoor	Use
	Operating temperature	0 ... +55 °C (32.... 131 °F)
	Storage temperature	-20 ... +70 °C (-4 158 °F)
	Relative humidity	max 95% RH non-condensing
PROTECTION RATING		IP20
ASSEMBLY	Positioning	Vertical
	Mount	On DIN 35 mm (1.38") rail
DIMENSIONS	(L x H x D)	25.4 x 92 x 90 mm (1" x 3.62" x 3.54")
WEIGHT		0.15 kg (0.33 lb)
EC REGULATIONS	EMC conformity (electromagnetic compatibility)	Compliance with the 2014/30/EU Directive EMC Emission: EN 61000-6-4 EMC Immunity: EN 61131-2, EN 61000-4-2, EN 61000-4-3, EN 61000-4-4, EN 61000-4-5, EN 61000-4-6, EN 61000-4-8, EN 61000-4-11
UL REGULATIONS		Compliance with UL508 standard

F-MIX module

INPUTS						
ANALOG	Number	4 configurable + 2 by amperometric transformer				
	Sensor type	TC, RTD (PT100, PT1000), IR sensor, linear DC				
	Single-ended voltage input	Voltage: 0...10 V, 0...2,5 V Impedance: >5 M Ω (channel 1: > 50 M Ω)				
	Differential voltage input	Voltage: 0...60 mV Impedance: >5 M Ω				
	Current input	Current: 0...20 mA, 4...20 mA Load: 100 Ω				
	Potentiometer input	Potentiometer resistance: 100 Ω min. Impedance: >5 M Ω (channel 1: > 50 M Ω)				
	Extensometer input	Voltage: -5...35 mV, -10...130 mV Impedance: > 5 M Ω				
	TC input (thermocouple)	Thermocouple: J, K, R, S, T, N, C, D, E, B, L (CJ internal) Impedance: > 5 M Ω				
	RTD input (thermoresistance)	Number of wires) 2, 3 or 4 Thermoresistance: PT100, PT1000				
	Input from a current transformer	rms current: 0...50 mA RMS Frequency: 50/60 Hz Impedance: 50 Ω				
	Temperature unit of measure	° C or ° F, selectable				
	Probe voltage	Voltage: stabilized 10 VDC or 1 VDC, selectable Current: 130 mA max				
	Resolution	16 bit				
		<i>Input type</i>	<i>Number</i>	<i>Min</i>	<i>Max</i>	<i>Resolution</i>
		Voltage 0...10 V	Number	0	65535	0,15 mV
		Voltage 0...2,5 V	Number	0	65535	0,04 mV
		Voltage 0...60 mV	Number	0	65535	0,9 μ V
		Current 0...20 mA	Number	0	65535	0,3 μ A
		Current 4...20 mA	Number	13107	65535	0,3 μ A
		Potentiometer	Number	0	65535	
	Extensometer -5...35 mV	Number	0	65535	0,6 μ V	
	Extensometer -10...130 mV	Number	0	65535	2,14 μ V	
	J thermocouple	°C °F	-210,0 -346	1200,0 2192	0,1 °C 0,2 °F	
	K thermocouple	°C °F	-270,0 -454	1372,0 2501	0,1 °C 0,2 °F	
	R thermocouple	°C °F	-50,0 32	1768,0 3182	0,1 °C 0,2 °F	
	S thermocouple	°C °F	-50,0 -58	1768,0 3214	0,1 °C 0,2 °F	
	T thermocouple	°C °F	-270,0 -454	400,0 752	0,1 °C 0,2 °F	
	N thermocouple	°C °F	-270,0 -454	1300,0 2372	0,1 °C 0,2 °F	
	C thermocouple	°C °F	0,0 32	2300,0 4172	0,1 °C 0,2 °F	
	D thermocouple	°C °F	0,0 32	2300,0 4523	0,1 °C 0,2 °F	
	E thermocouple	°C °F	-270,0 -454	1000,0 1832	0,1 °C 0,2 °F	
	B thermocouple	°C °F	44,0 32	1800,0 3272	0,1 °C 0,2 °F	
	L thermocouple	°C °F	-200,0 -328	900,0 1652	0,1 °C 0,2 °F	
	RTD PT100	°C °F	-200,0 -328	850,0 1562	0,1 °C 0,2 °F	
	RTD PT1000	°C °F	-200,0 -328	850,0 1562	0,1 °C 0,2 °F	
	TA	mA	0,0	50,0	0,01 mA	

ANALOG	Accuracy	<p>TC input (*) Note 1 Calibration: < ±(0,25% of value read in °C + 0,1 °C / 0,2 °F) Linearisation 1,8 % of value read Cold joint: < ±1 °C (34,7 °F) at 25 °C (77 °F) room temperature Cold joint compensation > 30:1 rejection at room temperature change</p> <p>RTD input Calibration: < ±(0.15% of value read + 0.4 °C / 0,72 °F) Linearisation: 0.1% of value read Thermal shift: < ±(0.005% of the value read in °C + 0.015°C / 0,072 °F) / °C starting from 25 °C (77 °F) room temperature</p> <p><u>Linear inputs:</u> Calibration: < 0.1% full scale Thermal shift: < ±0.005% full scale / °C starting from 25 °C (77 °F) room temperature</p> <p><u>CT input</u> Calibration : <0,5% full scale Thermal shift : <+/- 0,01% full scale/°C starting from 25°C (77 °F)</p>
	Conversion time	5 ms
	Protection	Polarity inversion Power surge: max 1 kV per 1 ms
	Electric insulation	Channel-bus: 2.0 kV
	Diagnostics	Module state: LED and software
DIGITAL	Number	8
	Voltage	Rated: 24 VDC (according to EN 61131-2 type 1 and type 3) Max: 32 V, 10 mA
	Switch limit	Low level: ≤ 8 VDC High level: ≥ 11 VDC
	Protection	Polarity inversion Power surge: max 1 kV per 1 ms
	Electric insulation	Channel-bus: 2.0 kV
	Diagnostics	Module state: LED and software Channel state: LED and software

(*) Note 1 : for TC S valid with T>100°C; for TC B valid with T>200°C

ANALOG

OUTPUTS	Number	2	
	Voltage output single-ended	±10 V, 15 mA max	
	Current output	0...20 mA, 4...20 mA Max load: 600 Ω	
	Resolution	16 bit	
	Format and resolution	<i>Output type</i>	<i>Number</i> <i>Min</i> <i>Max</i> <i>Resolution</i>
		±10 V	<i>Number</i> -32768 32767 0.3 mV
		0...20 mA	<i>Number</i> 0 32767 0.6 µA
	4...20 mA	<i>Number</i> 6550 32767 0.6 µA	
	Accuracy	Calibration precision: ±0,1% full scale @ 25 °C (77 °F)	
	Conversion time	5 ms	
	Adjustment time	100 µs	
	Protection	Short circuit: ±10 V Overload ±10 V: 16 mA max per each channel Open circuit 0...20 mA / 4...20 mA: Alarm status for open circuit Power surge: max 1 kV per 1 ms	
	Electric insulation	Channel-channel: No Channel-bus: 2.0 kV	
Diagnostics	Module state: LED and software Channel state: LED and software		
DIGITAL	Number	8	
	Voltage	24 VDC ±25%	
	Current	Single output: 1 A max Total outputs: 4 A max	
	Groups	1 group with 8 outputs	
	Protection	Short circuit Overload per output @ I ≥ 2,2 A for 500 ms min. Over temperature Power surge: max 1 kV per 1 ms	
	Electric insulation	Channel-bus: 2.0 kV	
	Diagnostics	Module state: LED and software Channel state: LED and software	

GENERAL DATA		
CHANNELS	Number	24
VOLTAGE	Operating voltage	24 VDC ±25%
	Current absorption	150 mA max
	Dissipated power	7.8 W
CONNECTIONS	Connector	Front 36 pole Wire connection with self-locking spring terminals, max cable section 0,2...1,5 mm ² (24...15 AWG)
ENVIRONMENTAL CONDITIONS	Indoor	Use
	Operating temperature	0 ... +55 °C (32 ...131 °F)
	Storage temperature	-20 ... +70 °C (-4 ...158 °F)
	Relative humidity	max 95% RH non-condensing
PROTECTION RATING		IP20
ASSEMBLY	Positioning	Vertical
	Mount	On DIN 35 mm (1.38") rail
DIMENSIONS	(L × H × D)	25,4 × 92 × 90 mm (1" × 3.62" × 3.54")
WEIGHT		0.13 kg (0.29 lb)
CERTIFICATIONS		CE, UL If the appropriate calibration is performed in the field, the Controller meets the requirements of standard AMS2750 and may be used in applications requiring the NADCAP directive

F-EU16 module

INPUTS		
DIGITAL	Number	8
	Voltage	Rated: 24 VDC (according to EN 61131-2 type 1 and type 3) Max: 32 V, 25 mA
	Switch limit	Low level: ≤ 8 VDC High level: ≥ 11 VDC
	Filter	Hardware: 100 Hz or 5 kHz selectable from software
	Protection	Polarity inversion Power surge: max 1 kV per 1 ms
	Electric insulation	Channel-bus: 2.0 kV
	Diagnostics	Module state: LED and software Channel state: LED and software
ANALOG		
DIGITAL	Number	8
	Groups	2 group with 4 outputs
	Voltage	24 VDC $\pm 25\%$
	Current	Single output: 2 A max Single group: 5 A max Total outputs: 8 A max
	Protection	Short circuit Overload per output @ $I \geq 2,2$ A for 500 ms min. Over temperature Power surge: max 1 kV per 1 ms
	Electric insulation	Channel-bus: 2.0 kV
	Diagnostics	Module state: LED and software Channel state: LED and software
GENERAL DATA		
CHANNELS	Number	16
VOLTAGE	Operating voltage	24 VDC $\pm 25\%$
	Current absorption	8 A max
	Dissipated power	9 W
CONNECTIONS	Connector	Front 26 pole Wire connection with self-locking spring terminals, max cable section 0,2...1.5 mm ² (24...15 AWG)
ENVIRONMENTAL CONDITIONS	Indoor	Use
	Operating temperature	0 ... +55 °C (32 ...131 °F)
	Storage temperature	-20 ... +70 °C (-4 ...158 °F)
	Relative humidity	max 95% RH non-condensing
PROTECTION RATING		IP20
ASSEMBLY	Positioning	Vertical
	Mount	On DIN 35 mm (1.38") rail
DIMENSIONS	(L x H x D)	25.4 x 92 x 90 mm (1" x 3.62" x 3.54")
WEIGHT		0.13 kg (0.29 lb)
CERTIFICATIONS		CE, UL

CONNECTION DIAGRAM

Interface connection diagram

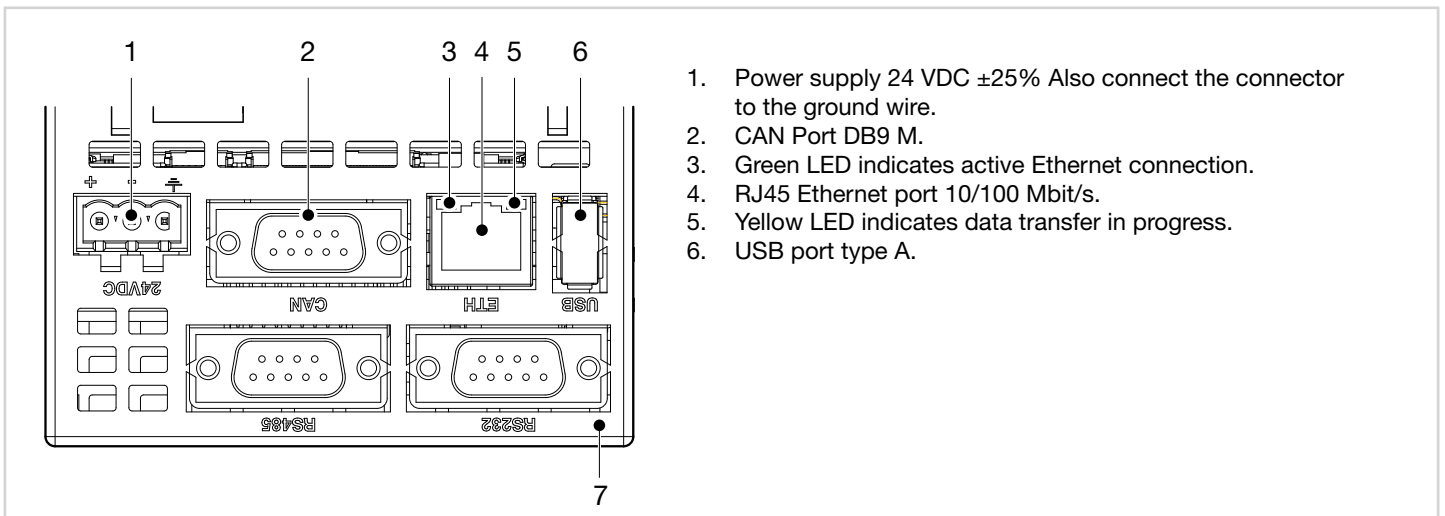

F-GCANs communication module connection diagram

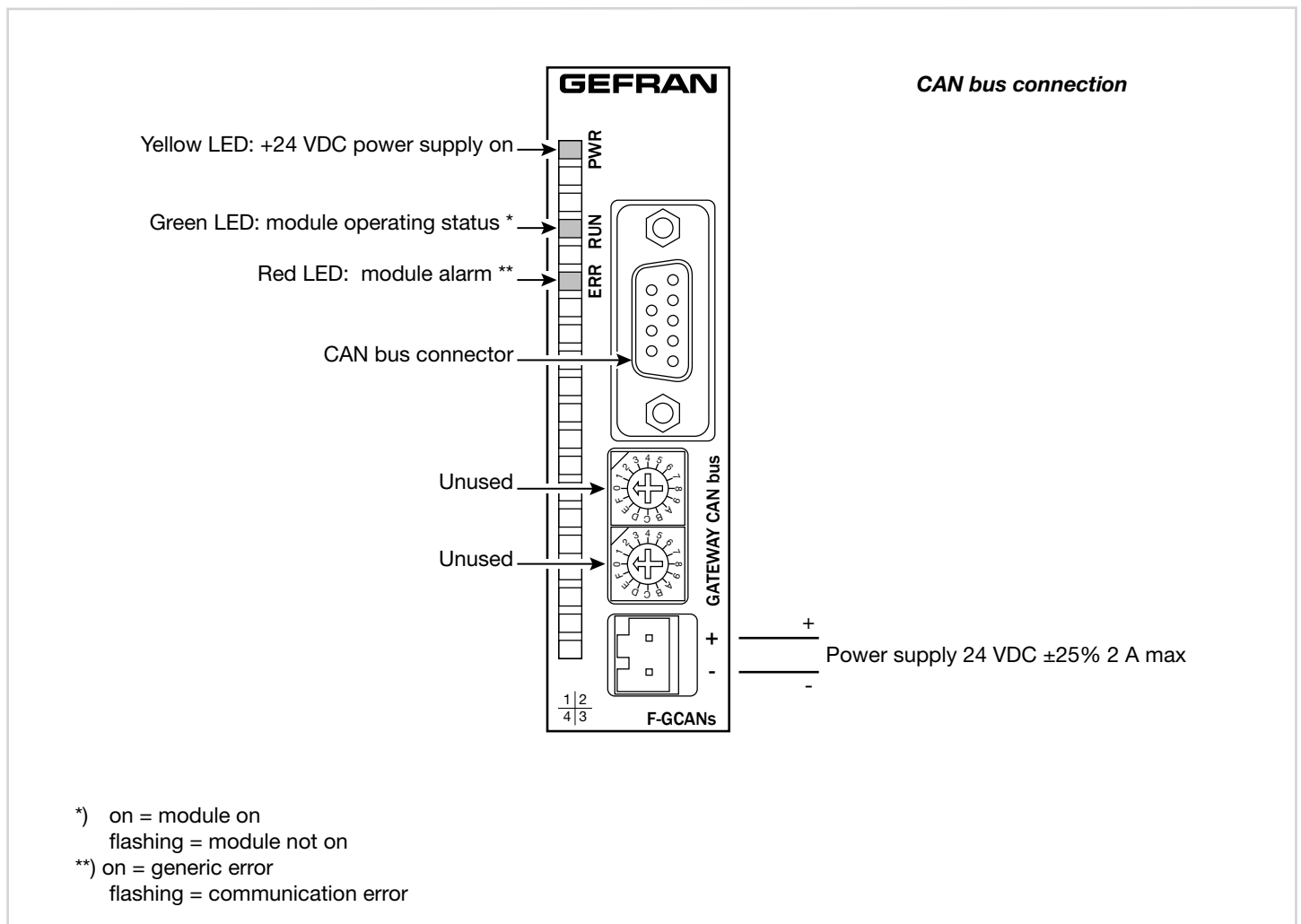

F-MIX module connection diagrams

General layout

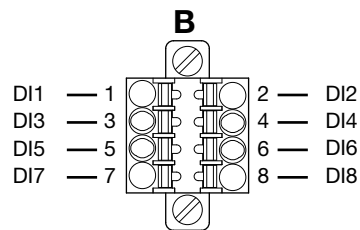
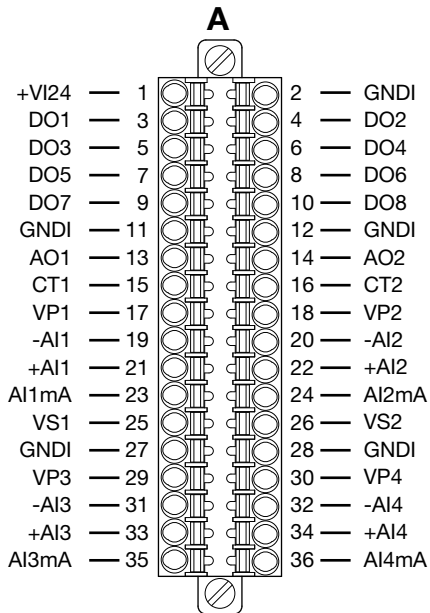
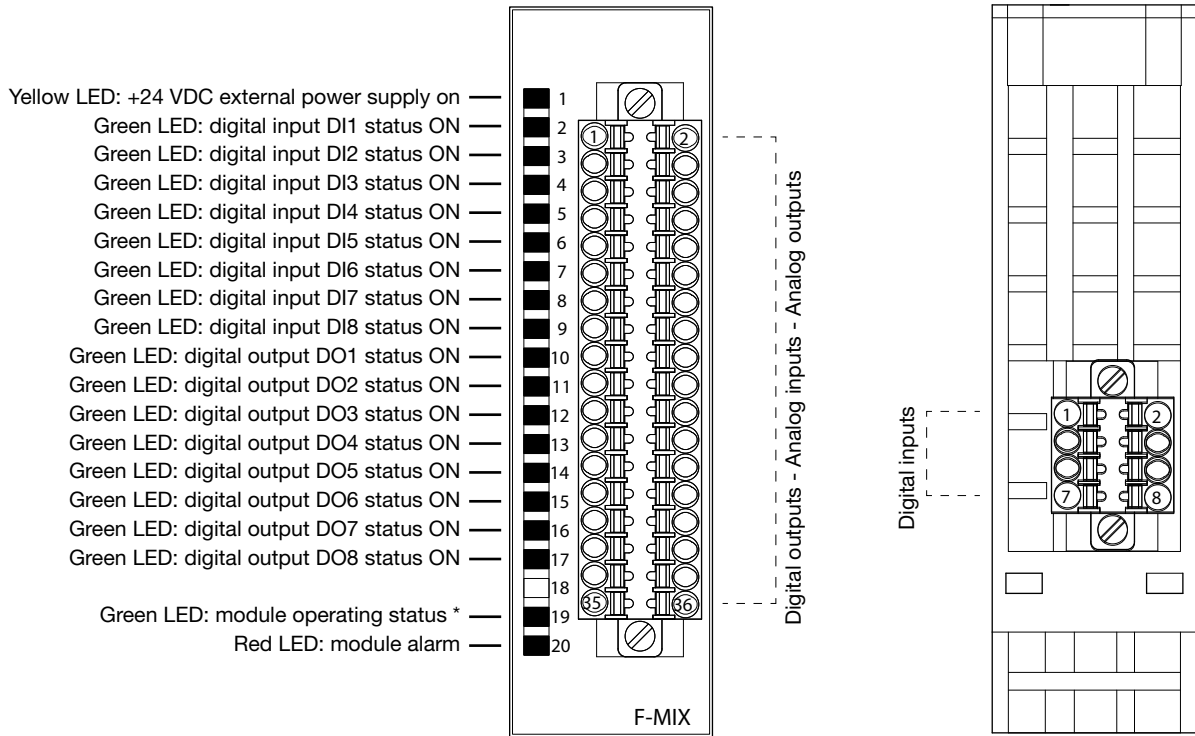

- DI = Digital input
- DO = Digital output
- AI = Analog input
- AO = Analog output
- +VI24 = 24 V voltage
- GNDI = 0 V voltage
- CT = input from a current transformer
- VP = Potentiometer power
- VS = Extensometer input

*) Fast flashing = module on
 slow flashing = module awaiting configuration (not operating)

1.1.1. Voltage

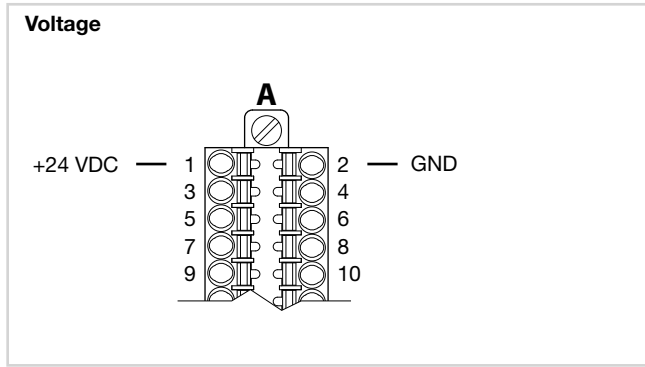

1.1.2. Digital inputs

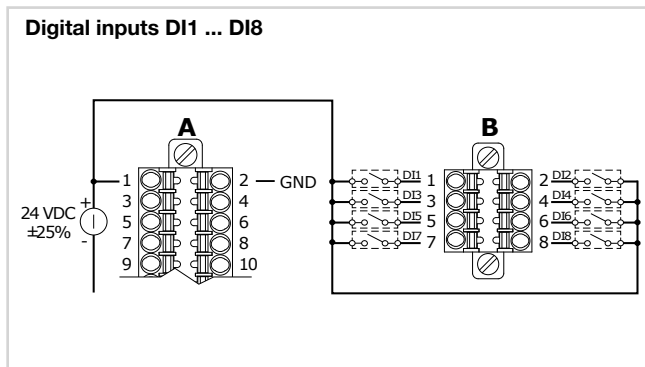

1.1.3. Analog inputs

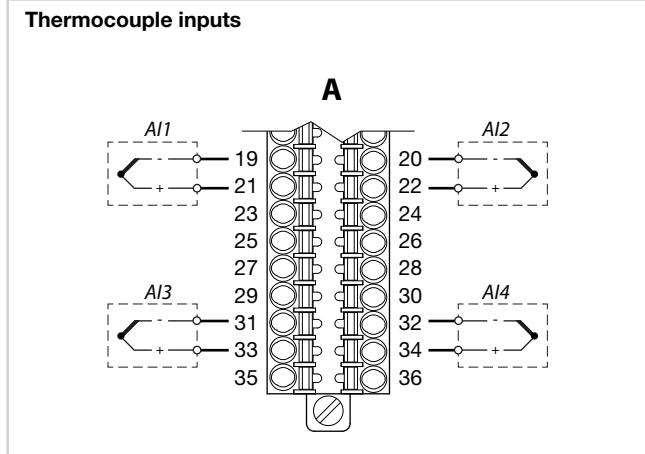
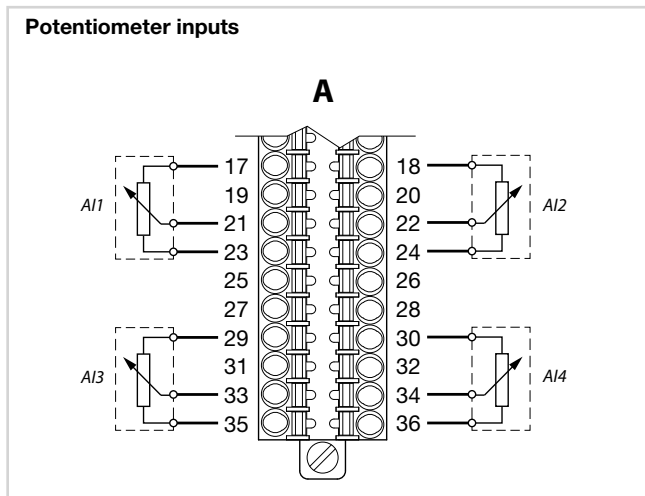

Inputs RTD PT100/PT1000 - 4-wire connection

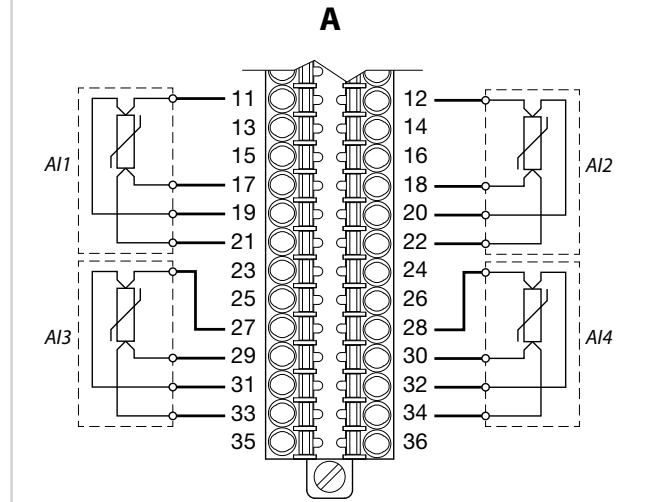

Inputs RTD PT100/PT1000 - 3-wire connection

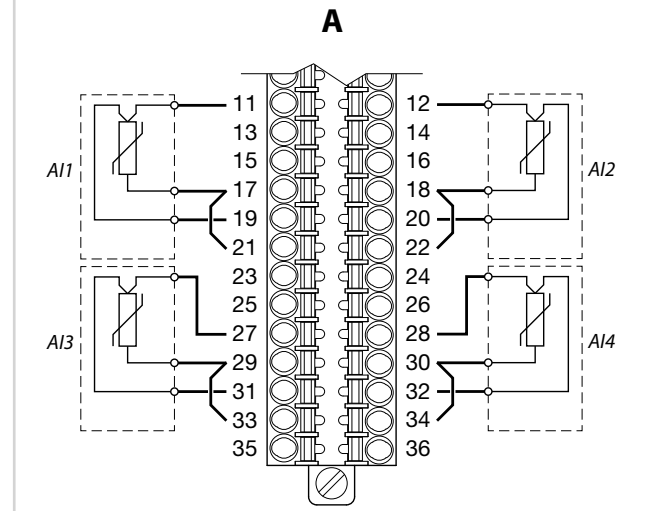

Inputs RTD PT100/PT1000 - 2-wire connection

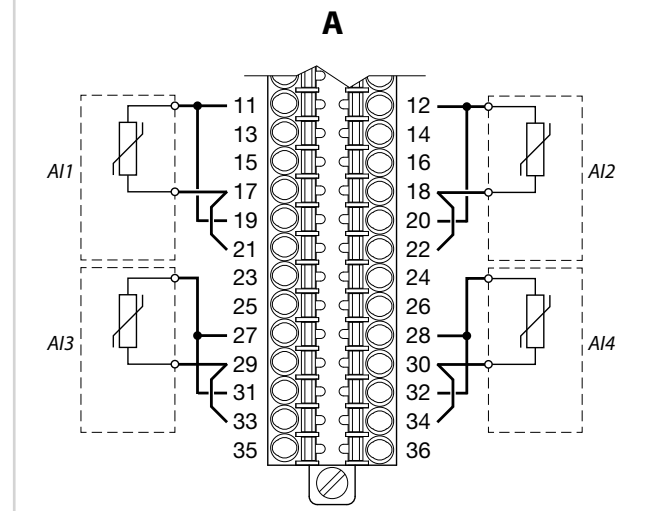

Single-ended voltage inputs

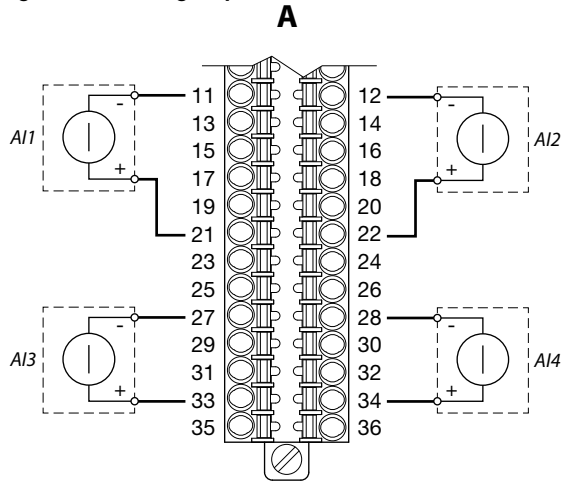

Current inputs

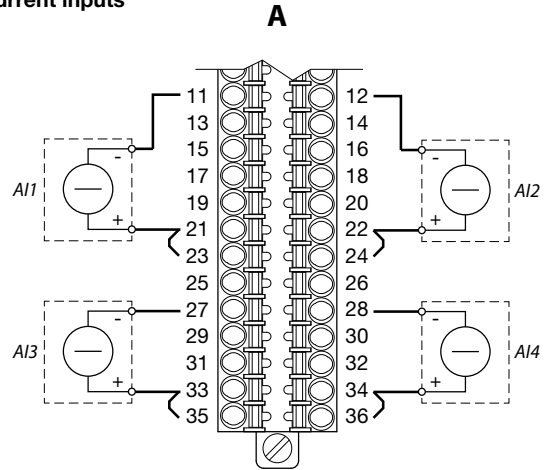

Differential voltage inputs

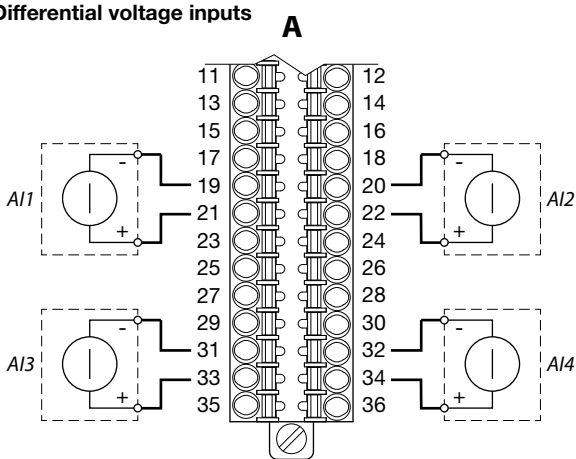

Amplified current transducer inputs - 4-wire connection

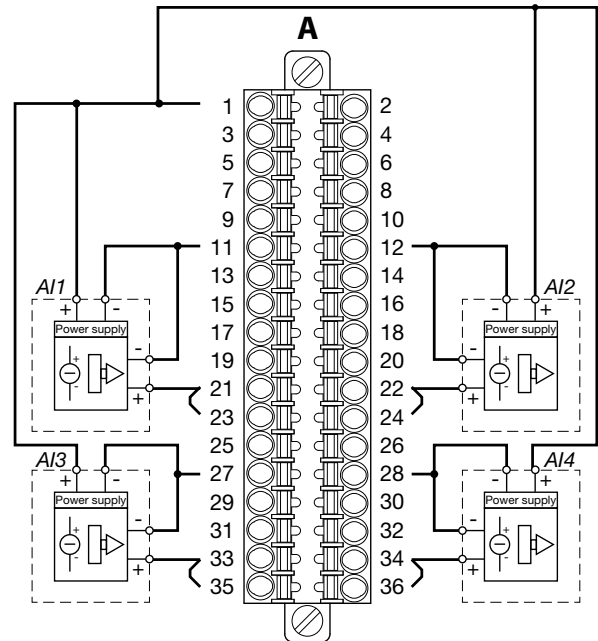

High impedance voltage input

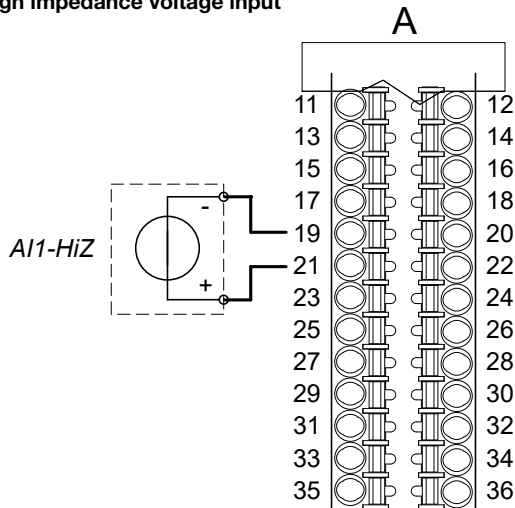

Amplified current transducer inputs - 2-wire connection

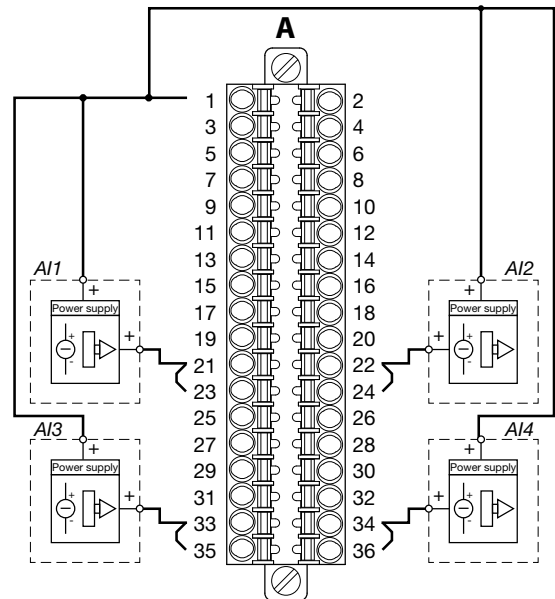

Current transformer inputs

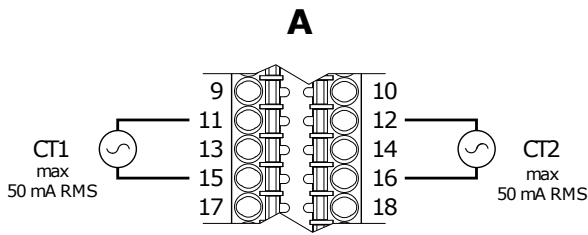

1.1.4. Digital outputs

1.1.5. Analog outputs

Digital outputs DO1 ... DO8

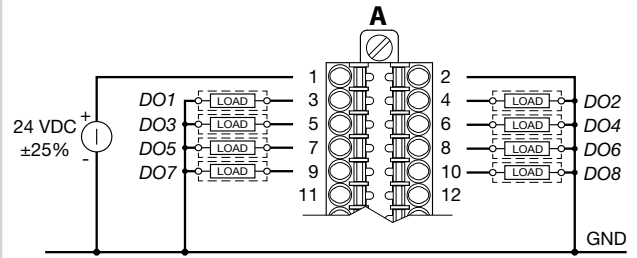

Analog outputs AO1 ... AO8

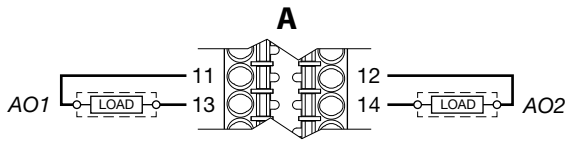

1.1. F-EU16 digital I/O module connection diagram

- Yellow LED: power supply for DO1-DO4 on
- Green LED: output DO1 status ON
- Green LED: output DO2 status ON
- Green LED: output DO3 status ON
- Green LED: output DO4 status ON
- Yellow LED: power supply for DO5-DO8 on
- Green LED: output DO5 status ON
- Green LED: output DO6 status ON
- Green LED: output DO7 status ON
- Green LED: output DO8 status ON

- Green LED: input DI1 status ON
- Green LED: input DI2 status ON
- Green LED: input DI3 status ON
- Green LED: input DI4 status ON
- Green LED: input DI5 status ON
- Green LED: input DI6 status ON
- Green LED: input DI7 status ON
- Green LED: input DI8 status ON
- Red LED: module alarm

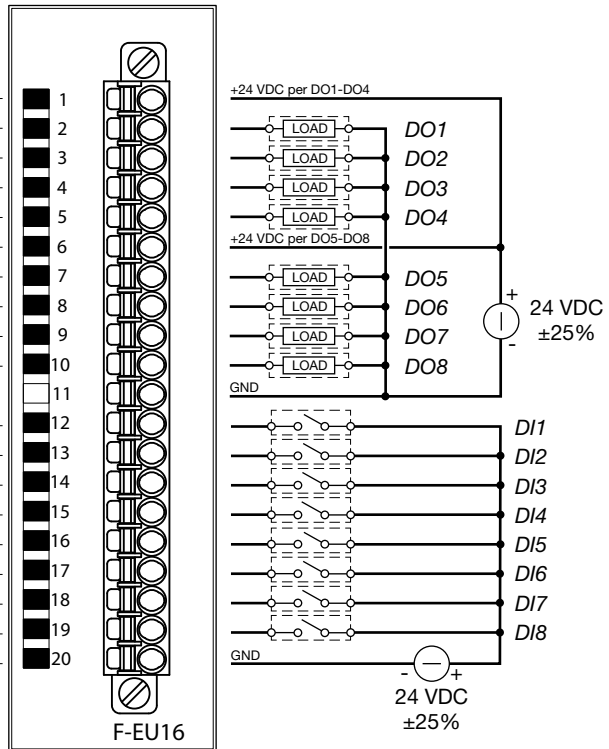

ORDER CODES

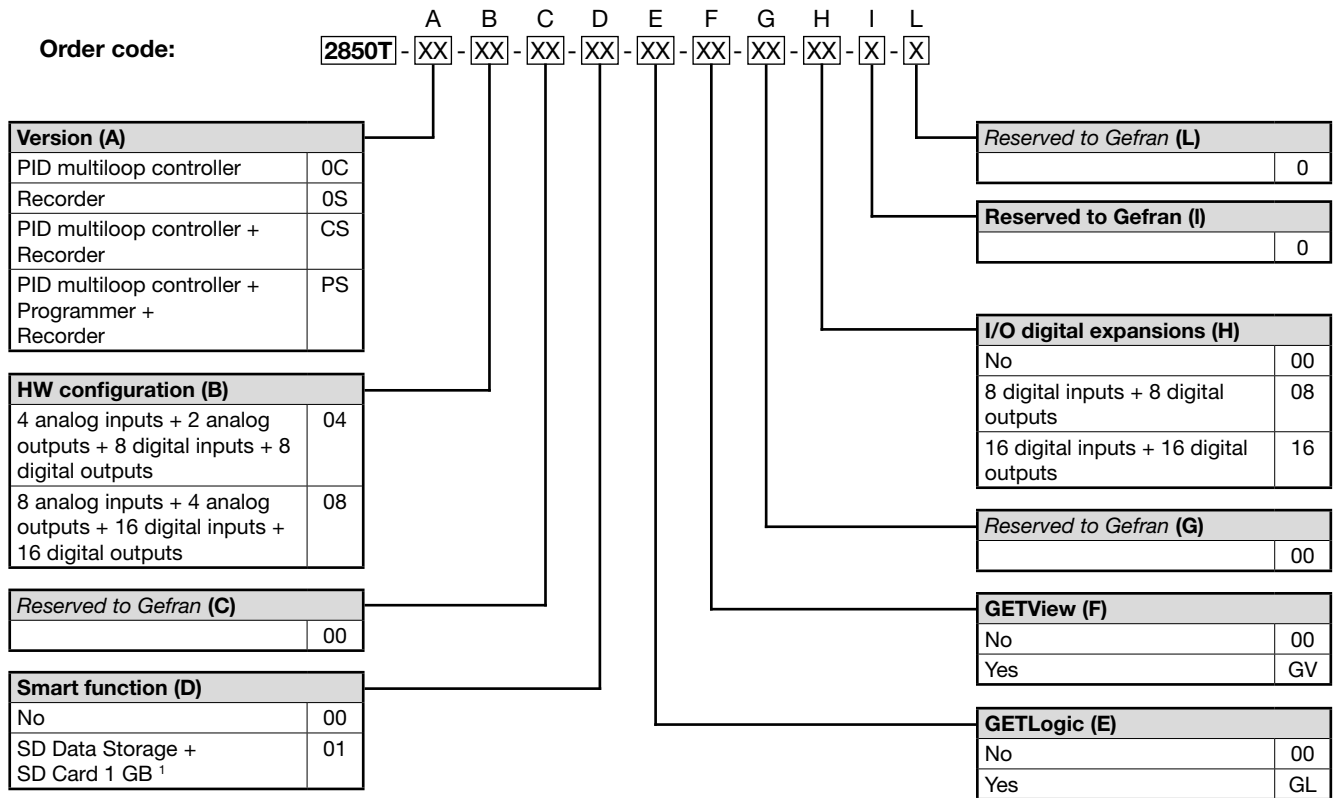

- 1) SD option includes a 1 GB SD Card
- The SD option is not available for the Multiloop model (0C)

ACCESSORIES

Code		Description
F067612		2 m communication cable
F068066		10 m communication cable
F069369	F-MIX	Module 4 AI + 2 AO + 8 DI + 8 DO
F067224	F-EU16	Module 8 DI + 8 DO
F035293	F-GCANs	CANOpen communication module
F057679	USB_PEN1G	1 GB USB key
F029933	GT_USBPAN	A-A USB extension with panel mount, IP65 cap and fastening screws
F057777	SD_CARD1G	1 GB SD Card

EAC	Conformity TC RU C-IT.ΓP01.B.01459
UL	Conformity C/UL/US File no. E216851
CE	EMC (electromagnetic compatibility): conforms to directiv 2014/30/EU with reference to standard EN 61326-1 emission in industrial environment class A Safety LVD: conforms to directiv 2014/35/EU with reference to standard EN61010-1

SOUTHWEST HEATER AND CONTROLS

10610 Control Place, Dallas Texas 75238

Main# 214-340-7500 Toll Free#: 800-687-2220 EMAIL: sales@swhc.com WEB: www.swhc.com