

# N120 Process Controller



**IDEAL FOR PANEL  
INSTALLATION**

**SELF-ADAPTIVE  
PID**

**RAMPS AND  
SOAKS**

**VERSATILE  
MEASUREMENT**

Complete and extremely versatile process controller arranged on a printed circuit board.

Accepts most sensors and signals used in the industry and provides the main types of output needed to operate in various processes.

A unique feature of this controller is its self-adaptive PID algorithm, which continuously adjusts the PID parameters in order to obtain the best possible performance for the process.

All controller configuration is done via the keyboard or via QuickTune configuration software, without any changes to the circuit.

## Electrical Connections

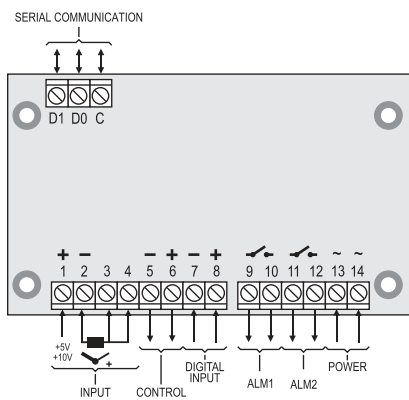

## Dimensions

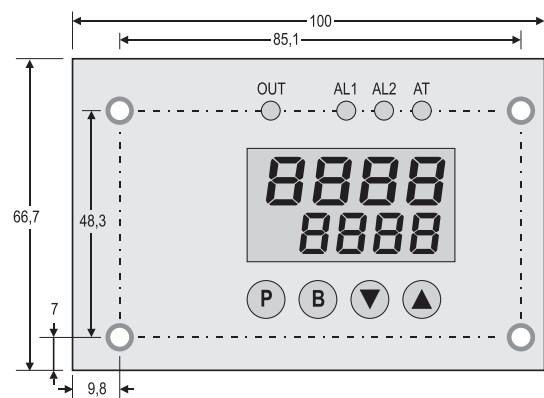

## How to Specify

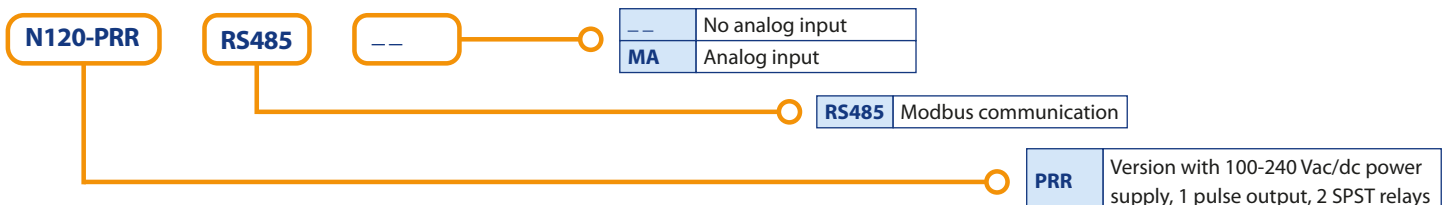

20230327 - FL - N120 - EN