

Heavy Duty Flanged Thermowell Series 401

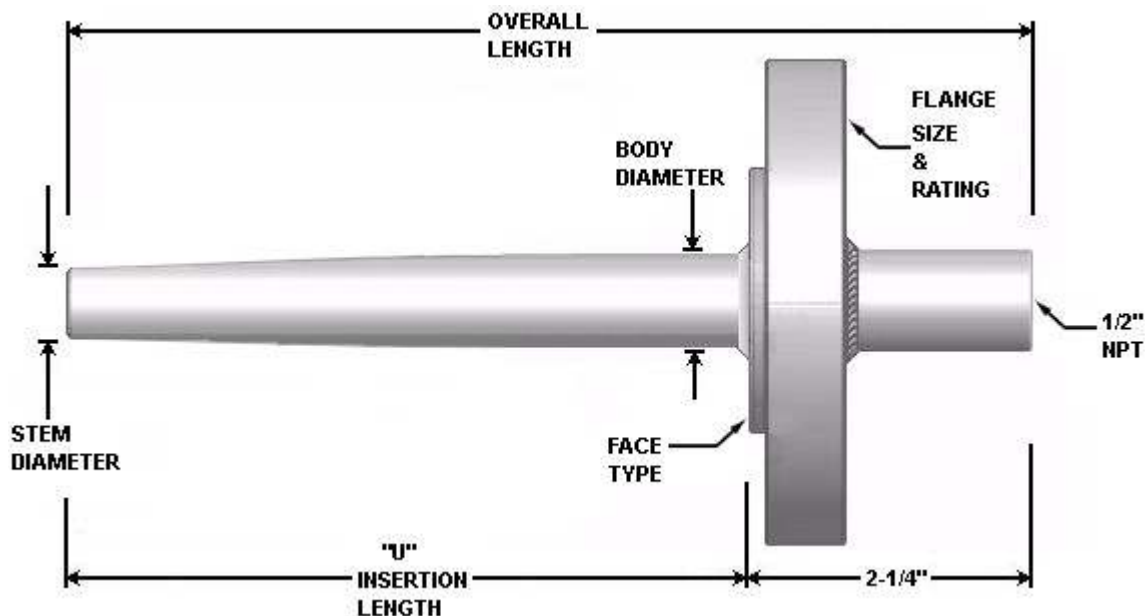

Ordering Information Part Number

① 401	② Bore Size	③ Well material	④ Flange Size	⑤ Flange Rating	⑥ Face type	⑦ "U" Insertion Length	⑧ "U" Insertion Length (Frac.In)
401							

②	Bore Size
G	.265"
H	.390"

③	Well Material
M	304SS
P	316 SS
Q	310 SS
R	316 L SS
S	410 SS
T	446 SS
K	Inconel 600 (Alloy 600)
W	Hastelloy B
X	Hastelloy C
Y	Carbon Steel
Z	Alloy 800 (Incoloy)

④	Flange Size
A	1"
B	1.5"
C	2"
D	2.5"
E	3"
F	1/2"
G	3/4"

⑤	Flange Rating
J	150#
K	300#
M	600#
N	900#
P	1500#
Q	2500#

⑥	Face type
1	Raised face
2	Ring type Joint
3	Flat face

⑦	"U" Insertion Length
002"-048"	Specify in Inches
Note	Over 048" contact factory

⑧	"U" Insertion Length (fractional in.)
A	0
B	1/8"
C	1/4"
D	3/8"
E	1/2"
F	5/8"
G	3/4"
H	7/8"

- **Not all bore sizes available in all configurations**
- **Stem diameter is determined by bore size**
- **Other well materials available**
- **Overall length is determined by the "U" dimension**

SOUTHWEST HEATER AND CONTROLS